

S E I K O

パーツリスト
PARTS LIST

PW-26B-1

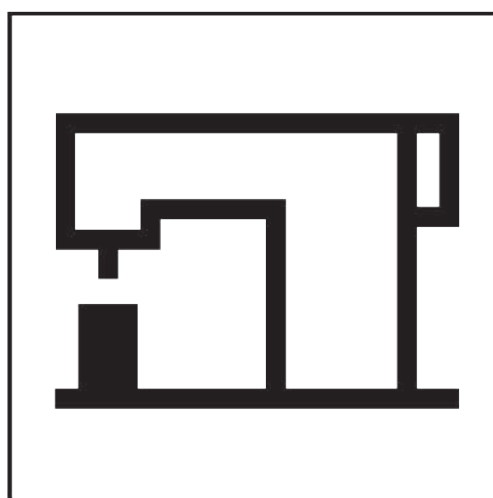

SEIKO SEWING MACHINE CO., LTD.

Notes for using this parts book

1. Parts supplied as complete assemblies are circled by a line .
2. This book was prepared based on information available in Sep. 2021.
3. Parts are subject changes in design without prior notice.

パーツブックご利用に際して

1. 組単位で補給する部品は、 線で示しております。
2. この本は2021年9月のデータに基づいて作成されたものです。
3. 部品は予告なしに設計変更される場合があります。

INDEX 目次

	pages
Face plate·Upper plate 面板·上板	1,2
Arm shaft·Thread take-up lever mechanism 上軸·天秤関係	3,4
Needle bar mechanism 針棒関係	5,6
Presser foot mechanism 押え関係	7,8
Feed mechanism 送り関係	9,10
Feed dog·Feed rock shaft 送り歯·送り軸	11,12
Lower shaft mechanism 下軸関係	13,14
Thread tension 糸調子関係	15,16
Hook·Hook bracket mechanism カマ·カマ土台関係	17,18
Accessories 付属品関係	19,20
Option parts 別売品	21,22
Table of gauge parts ゲージ表	23

面板·上板/Face plate·Upper plate

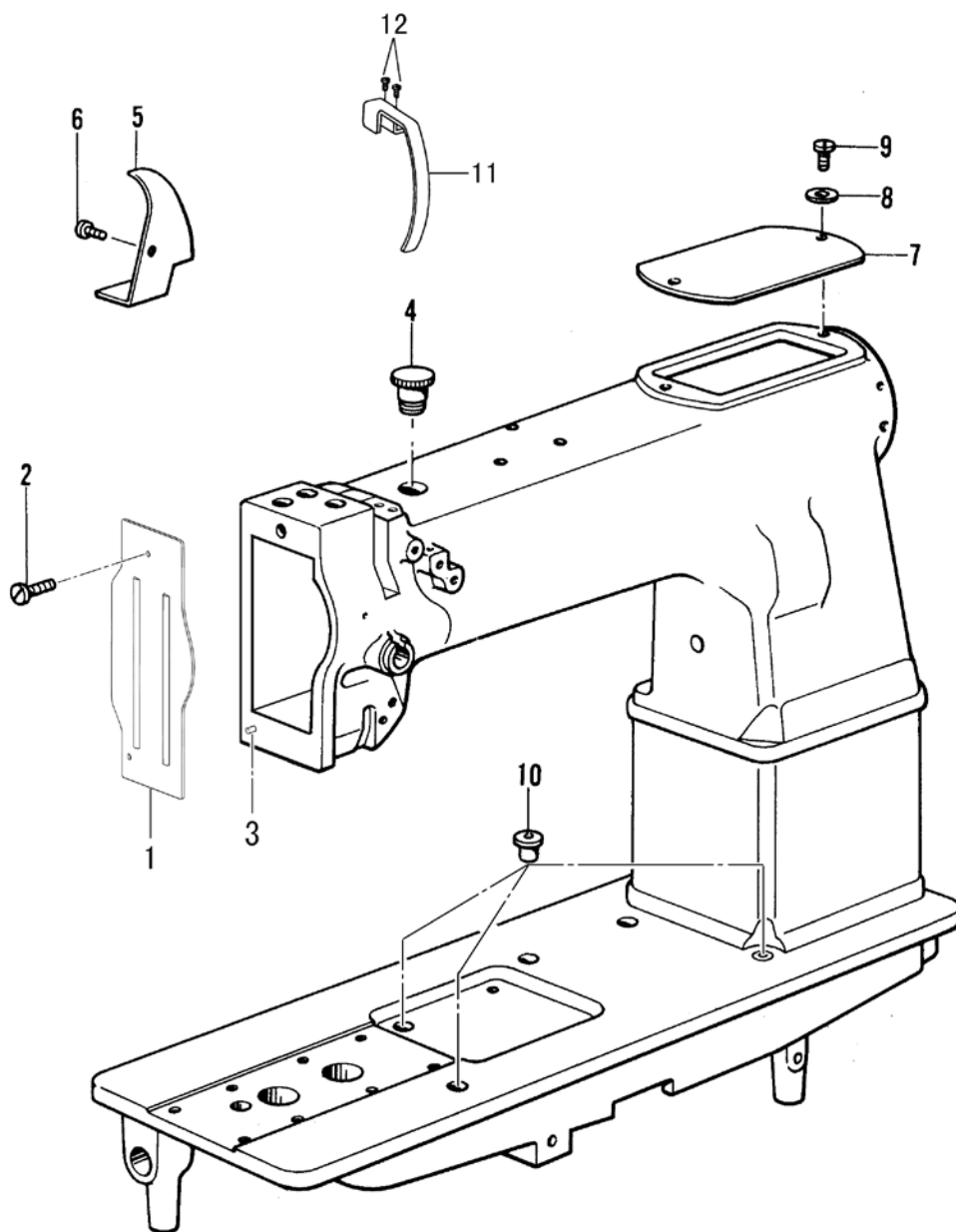

面板・上板/Face plate·Upper plate

No.	部品番号	数量	品名	PARTS NAME
	PARTS No.	QTY		
1	25107	1	面板	FACE PLATE
2	25108	1	止めねじ	SCREW SM9/64X40
3	25120	1	面板ピン	POSITIONING PIN
4	25112	1	油穴栓	OIL CAP
5	10551	1	天秤油受け	THREAD TAKE-UP LEVER OIL GUARD
6	25109	1	止めねじ	SCREW SM9/64X40 L=4.5
7	25113	1	上板	UPPER PLATE
8	25115	1	座金	WASHER
9	25114	1	段ねじ	HINGE SCREW SM3/16X28 L=8.5
10	25124	3	オイルカップ	OIL CAP
11	25110	1	天秤ガード	THREAD TAKE-UP LEVER COVER
12	25111	2	止めねじ	SCREW SM9/64X40 L=9

上軸・天秤關係 / Arm shaft · Thread take-up lever mechanism

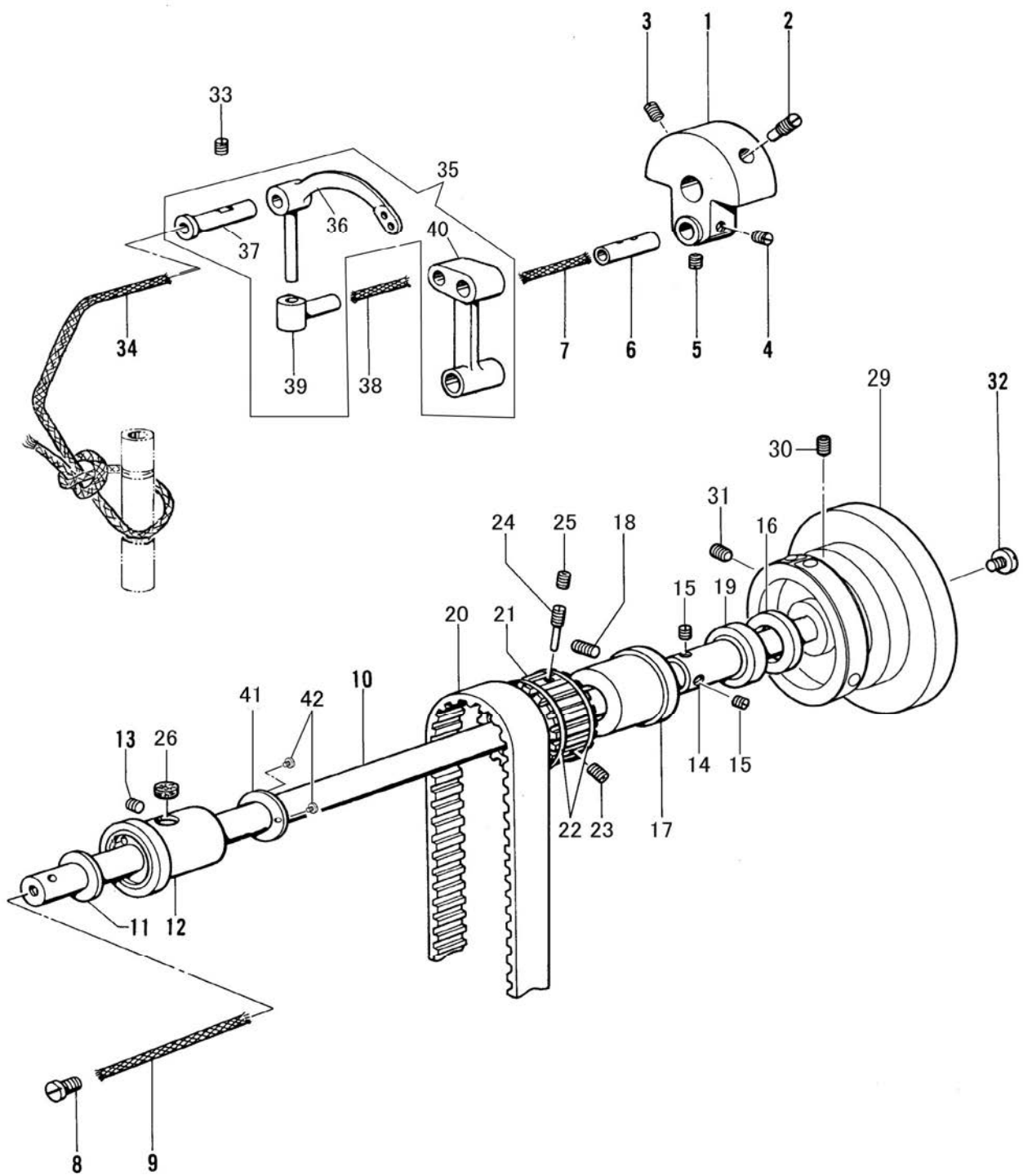

上軸・天秤関係/Arm shaft・Thread take-up lever mechanism

No.	部品番号	数量	品名	PARTS NAME
	PARTS No.	QTY		
1	19414	1	クランクモーションカム	CRANK MOTION CAM
2	25186	1	位置決めねじ	POSITION SCREW SM1/4X28 L=20
3	25185	1	止めねじ	SET SCREW SM1/4X28 L=14
4	25184	1	止めねじ	SET SCREW SM1/4X28 L=6.5
5	25183	1	止めねじ	SET SCREW SM1/4X28 L=4
6	10523	1	針棒クランクピン	NEEDLE BAR CRANK PIN
7	25182	1	油芯	OIL WICK
8	25187	1	栓ねじ	SCREW SM5/16X24 L=6
9	25188	1	油芯	OIL WICK
10	25190	1	上軸	ARM SHAFT
11	10563	1	上軸メタルワッシャー	CRANK WASHER
12	10562-A	1	上軸メタル(前)	ARM SHAFT BUSHING (FRONT)
13	25184	1	止めねじ	SET SCREW SM1/4X28 L=6.5
14	25199	1	上軸ベアリングカラー	ARM SHAFT BEARING ADAPTER SLEEVE
15	25196	2	止めねじ	SET SCREW SM1/4X32 L=20
16	25198	1	リング	RING
17	13074	1	上軸ベアリングケース	ARM SHAFT BEARING ADAPTER
18	25170	1	止めねじ	SET SCREW 17/64X32 L=5.5
19	25197	1	ベアリング	BEARING
20	25206	1	タイミングベルト	ARM SHAFT CONNECTING BELT
21	25192	1	上軸ベルトプーリー	ARM SHAFT BELT PULLEY
22	25191	2	プーリーリング	PULLEY RING
23	17019A	1	止めねじ	SET SCREW SM1/4X40 L=8
24	25193	1	位置決めねじ	POSITION SCREW SM1/4X40 L=32
25	17019A	1	止めねじ	SCREW SM1/4X40 L=8
26	25189	1	フェルト	FELT
29	25200	1	プーリー	PULLEY
30	25205	1	位置決めねじ	POSITION SCREW SM15/64X28 L=21
31	25203	1	止めねじ	SET SCREW SM15/64X28 L=20
32	25204	1	押しねじ	SCREW SM11/32X28 L=11
33	25179	1	止めねじ	SET SCREW 17/64X32 L=9
34	25180	1	油芯	OIL WICK
35	10905C	1	天秤(組)	THREAD TAKE-UP LEVER COMPLETE
36	10905	1	天秤	THREAD TAKE-UP LEVER
37	10527	1	天秤ピン	THREAD TAKE-UP LEVER HINGE STUD
38	25181	1	油芯	OIL WICK
39	10529	1	天秤抱き	THREAD TAKE-UP LEVER DRIVING STUD
40	10528	1	針棒クランクロッド	NEEDLE BAR CONNECTING LINK
41	25312	1	ワッシャー	WASHER
42	14013	2	止めねじ	SCREW SM9/64X40 L=5

針棒關係/Needle bar mechanism

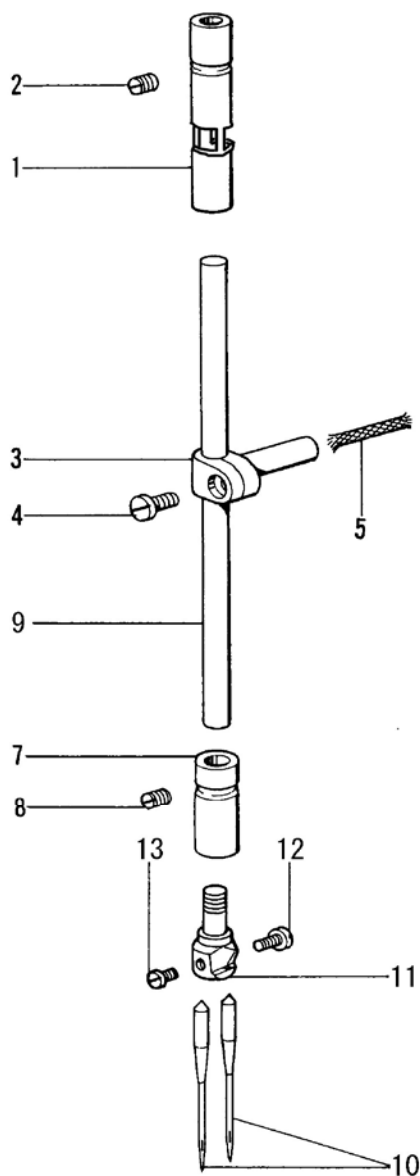

針棒関係/Needle bar mechanism

No.	部品番号	数量	品名	PARTS NAME
	PARTS No.	QTY		
1	25313	1	針棒メタル(上)	NEEDLE BAR BUSHING (UPPER)
2	25170	1	止めねじ	SET SCREW 17/64X32 L=20
3	25172	1	針棒抱き	NEEDLE BAR CONNECTING STUD
4	25173	1	締めねじ	PINCH SCREW M4X0.7 L=9
5	25181	1	油芯	OIL WICK
7	25174	1	針棒メタル(下)	NEEDLE BAR BUSHING (LOWER)
8	25170	1	止めねじ	SET SCREW 17/64X32 L=20
9	10992	1	針棒	NEEDLE BAR
10	N1314	2	針 DP-F22 #14	NEEDLE DP-F22 #14
11	11201-R	1	針株 3/32"(標準)	NEEDLE CLAMP 3/32"(STANDARD)
針株 11201-R用 / FOR NEEDLE CLAMP 11201-R				
12	10535	1	針止め(右)	SET SCREW 3.4X36(FOR RIGHT SIDE NEEDLE)
13	15823	1	針止め(左)	SET SCREW 3.4X36(FOR LEFT SIDE NEEDLE)
針株 12067用 / FOR NEEDLE CLAMP 12067				
12	12076	1	針止め(右)	SET SCREW 1/8X40(FOR RIGHT SIDE NEEDLE)
13	12076	1	針止め(左)	SET SCREW 1/8X40(FOR LEFT SIDE NEEDLE)
針株 14557-R用 / FOR NEEDLE CLAMP 14557-R				
12	10535	1	針止め(右)	SET SCREW 3.4X36(FOR RIGHT SIDE NEEDLE)
13	10535	1	針止め(左)	SET SCREW 3.4X36(FOR LEFT SIDE NEEDLE)

押え関係/Presser foot mechanism

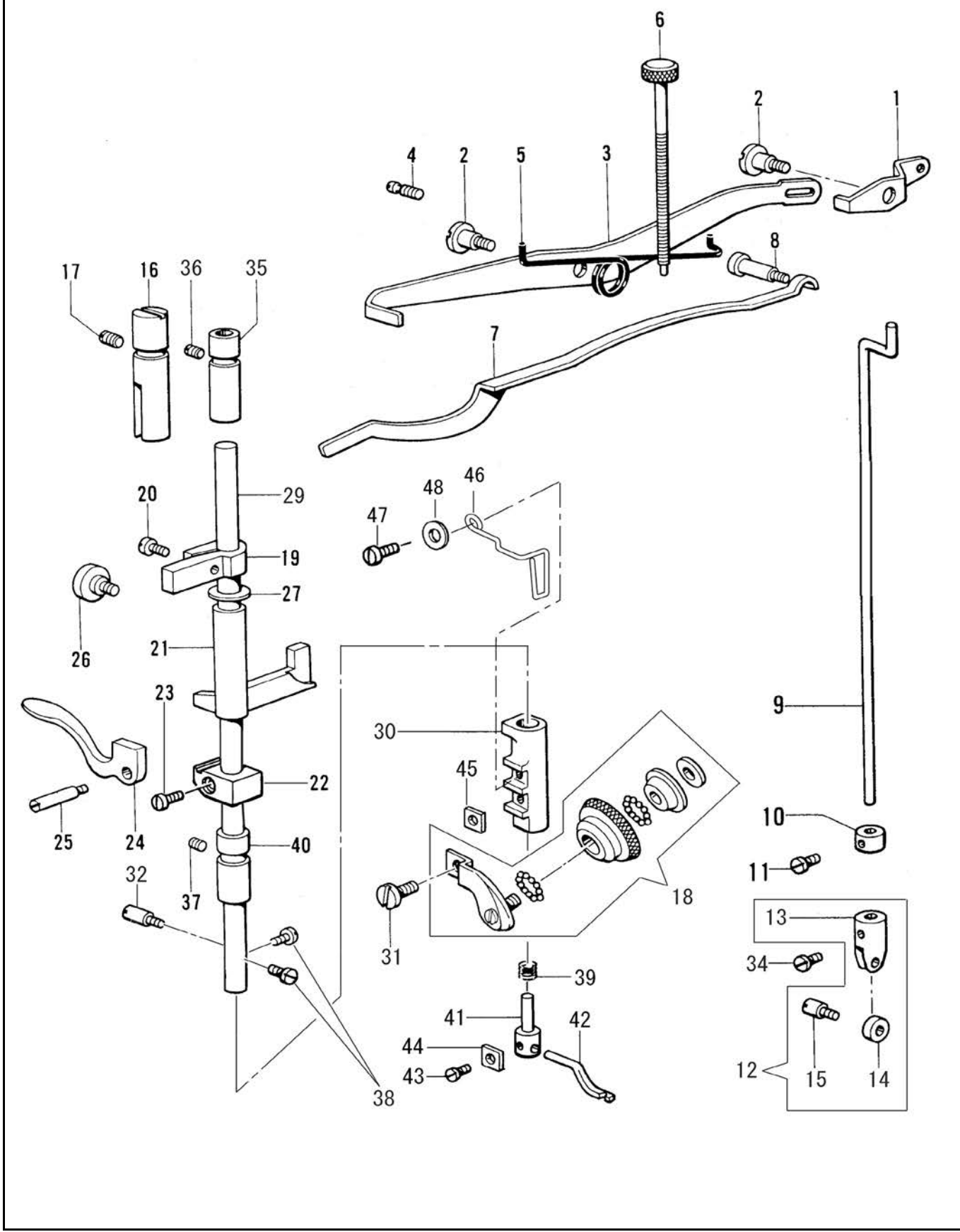

押え関係/Presser foot mechanism

No.	部品番号	数量	品名	PARTS NAME
	PARTS No.	QTY		
1	25227	1	小弓	KNEE LIFTER CONNECTING LEVER
2	25224	2	段ねじ	HINGE SCREW
3	10710	1	大弓	KNEE LIFTER LIFTING LEVER
4	25223	1	弓ばね掛け	SCREW SM1/4X28
5	25226	1	弓ばね	SPRING
6	25225	1	大板ばね調節ねじ	REGULATING SCREW 17/64X32 L=88
7	25220	1	大板ばね	PRESSER BAR SPRING (FLAT)
8	25221	1	段ねじ	STUD SCREW SM1/4X28 L=31
9	25228	1	吊り棒	KNEE LIFTER CONNECTING LEVER LIFTING ROD
10	25229	1	吊り棒カラー	LIFTING ROD COLLAR
11	25230	1	止めねじ	SCREW SM11/64X32 L=8
12	25232C	1	吊り棒土台(組)	LIFTING ROD BRACKET COMPLETE
13	25232	1	吊り棒土台	LIFTING ROD ROLLER BRACKET
14	25233	1	吊り棒土台ローラー	LIFTING ROD ROLLER
15	25234	1	ピンねじ	ROLLER SET SCREW SM9/64X40 L=13
16	10543	1	案内棒	PRESSER BAR POSITION GUIDE
17	25163	1	止めねじ	SET SCREW 17/64X32 L=11
18	25217	1	ローラー押え(組) φ32	ROLLER PRESSER FOOT COMPLETE, φ32
19	25208	1	押え棒案内	PRESSER BAR POSITION GUIDE BRACKET
20	25209	1	締めねじ	PINCH SCREW 9/64X40 L=7
21	25211	1	押え棒抱き	PRESSER BAR LIFTING BRACKET
22	13360	1	大板ばね受け	PRESSER BAR SPRING BRACKET
23	25173	1	締めねじ	PINCH SCREW M4X0.7 L=9
24	10659	1	押え上げレバー	PRESSER BAR LIFTER
25	25164	1	ピンねじ	HINGE SCREW SM1/4X28 L=24
26	25210	1	段ねじ	LIFTING BRACKET GUIDE SCREW SM1/4X40 L=16.5
27	25314	1	ばね座金	SPRING WASHER
29	25207	1	ローラー押え棒	ROLLER PRESSER BAR
30	25214	1	ローラー押え土台	ROLLER PRESSER BAR BRACKET
31	25218	1	ローラー押え止めねじ	ROLLER PRESSER FOOT SCREW
32	25213	1	位置決めねじ	POSITION SCREW
34	25231	1	止めねじ	SCREW SM11/64X32 L=8
35	10538	1	押え棒メタル(上)	PRESSER BAR BUSHING (UPPER)
36	25170	1	止めねじ	SET SCREW 17/64X32 L=20
37	25170	1	止めねじ	SET SCREW 17/64X32 L=20
38	25177	2	押え棒ピン止めねじ	PRESSER BAR PIN SET SCREW
39	25215	1	土台スプリング	SPRING
40	25212	1	押え棒メタル(下)	PRESSER BAR BUSHING (LOWER)
41	12072	1	補助押え(小)土台	SUB PRESSER FOOT BRACKET
42	15844	1	補助押え 3/32"(標準)	SUB PRESSER FOOT 3/32"(STANDARD)
43	3052	1	止めねじ	SCREW
44	12073	1	補助押え止め板	SUB PRESSER FOOT STOPPER PLATE
45	12731	1	ホルダー受け板 3/32"(標準)	ROLLER HOLDER SPACER 3/32"(STANDARD)
46	12079	1	フィンガーガード	FINGER GUARD
47	12069	1	止めねじ	SCREW SM11/64X32 L=6
48	30078	1	ワッシャー	WASHER

送り関係/Feed mechanism

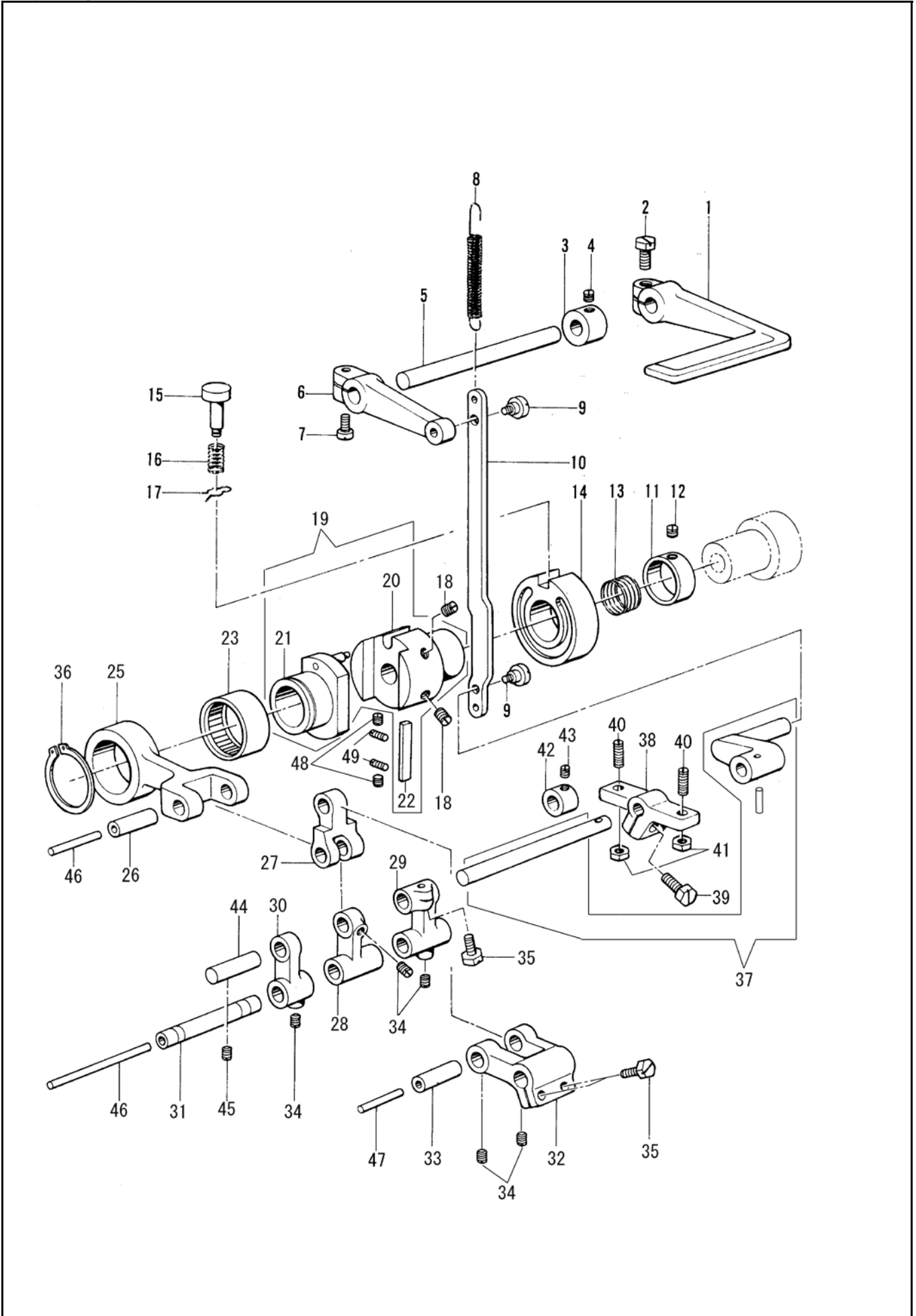

送り関係/Feed mechanism

No.	部品番号	数量	品名	PARTS NAME
	PARTS No.	QTY		
1	25235	1	バックレバー	FEED REVERSING LEVER
2	10845	1	締めねじ	PINCH SCREW SM15/64X28 L=18
3	25270	1	カラー	COLLAR
4	25271	1	止めねじ	SET SCREW SM15/64X28 L=8
5	25269	1	バックレバー軸	FEED REVERSING LEVER SHAFT
6	25265	1	バックレバー軸だるま	FEED REVERSING LEVER SHAFT CRANK
7	25267	1	締めねじ	PINCH SCREW SM15/64X28 L=7
8	25268	1	バックレバースプリング	SPRING
9	25274	2	段ねじ	HINGE SCREW SM1/4X28
10	25273	1	バック連結ロッド	FEED REVERSING CONNECTING ROD
11	25250	1	押しリング	RING
12	25196	2	止めねじ	SET SCREW SM1/4X32 L=5.5
13	25249	1	押しリングスプリング	SPRING
14	25248	1	渦巻きカム	ADJUSTING DISC
15	25320	1	押しボタン	FEED REGULATING STUD (SMALL)
16	25321	1	押しボタンスプリング	SPRING
17	25322	1	押しボタン止めピン	PIN
18	10766-G	2	止めねじ	SET SCREW SM1/4X32 L=12
19	25246C	1	送りカム(組)	FEED DRIVING CAM COMPLETE
20	25246	1	送りカム土台	FEED DRIVING FLANGE
21	25245	1	送りカム	FEED DRIVING CAM
22	25247	1	案内板	FEED DRIVING ECCENTRIC FRICTION GIBE
23	25244	1	ニードルベアリング	NEEDLE BEARING
25	11951	1	下送りロッド	FEED DRIVING ECCENTRIC CONNECTION
26	11962	1	下送りロッドピン	HINGE PIN
27	11955	1	二又リンク	FEED DRIVING ECCENTRIC CONNECTION LINK
28	11956	1	連結リンク	FEED REVERSING SHAFT CRANK LINK
29	16707	1	切り換えクランク(右)	FEED REVERSING SHAFT CRANK
30	11958	1	切り換えクランク(左)	FEED REVERSING MECHANISM SUPPORT LINK
31	31029	1	ピン	STUD
32	16708	1	連結レバー	FEED ROCK SHAFT CRANK
33	11962	1	ピン	FEED ROCK SHAFT CRANK STUD
34	11953	5	止めねじ	SET SCREW SM7/32X32 L=5
35	19420	3	締めねじ	PINCH SCREW SM1/4X24 L=23
36	25243	1	止め輪	SNAP RING
37	25275C	1	バック土台軸ホルダー(組)	FEED REVERSING SHAFT COMPLETE
38	25261	1	スタッド	FEED REVERSING SHAFT BRACKET
39	19420	1	締めねじ	PINCH SCREW SM1/4X28 L=16
40	25263	2	調節ねじ	REGULATING SCREW M5X0.8
41	25264	2	ナット	NUT
42	25276	1	カラー	COLLAR
43	25277	2	止めねじ	SET SCREW SM1/4X32 L=4.5
44	11950	1	ピン	FEED REVERSING MECHANISM SUPPORT LINK STUD
45	25325	1	止めねじ	SET SCREW SM1/4X32
46	25260	2	油芯	OIL WICK
47	25258	1	油芯	OIL WICK
48	10630	2	止めねじ	SET SCREW SM1/8X40 L=5
49	10629	2	止めねじ	SET SCREW SM1/8X40 L=8

送り歯・送り軸/Feed dog・Feed rock shaft

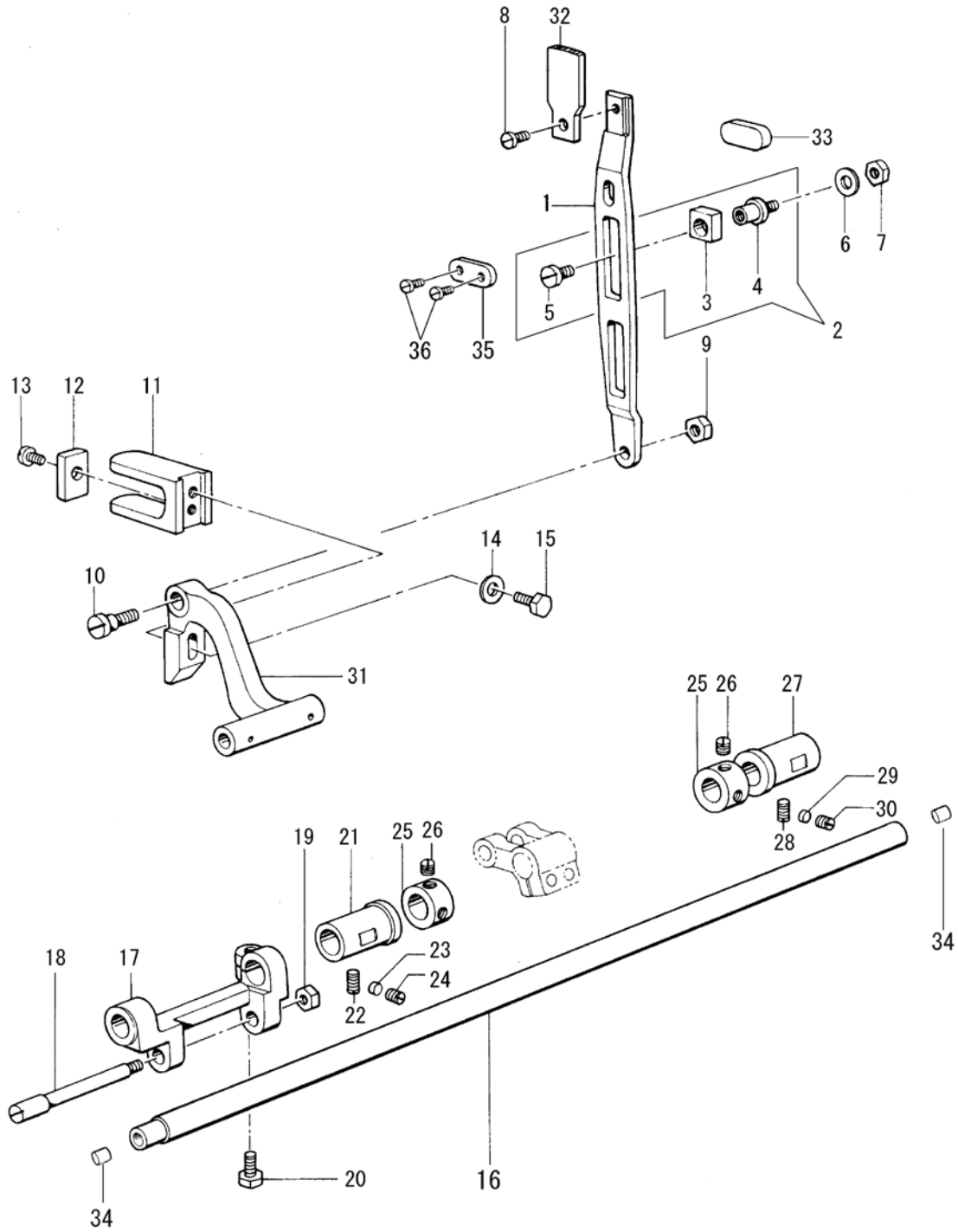

送り歯・送り軸/Feed dog·Feed rock shaft

No.	部品番号	数量	品名	PARTS NAME
	PARTS No.	QTY		
1	12127	1	送り板	FEED PLATE
2	12128C	1	送り板角玉(組)	FEED PLATE SLIDE BLOCK COMPLETE
3	12128	1	送り板角玉	FEED PLATE SLIDE BLOCK
4	12129	1	送り板角玉段ねじ	STUD SCREW SM7/32X32
5	6339	1	止めねじ	SCREW SM1/8X44 L=4
6	25316	1	座金	WASHER
7	25151	1	ナット	NUT
8	25127	1	締めねじ	SCREW SM11/64X32 L=6.5
9	25158	1	ナット	NUT
10	25159	1	段ねじ	HINGE SCREW
11	10595	1	コの字	FEED LIFTING CAM FORK
12	10596	1	フェルト	OILING FELT
13	10597	1	止めねじ	SCREW SM1/8X40 L=3.3
14	10599	1	座金	WASHER
15	70129	1	止めねじ	SCREW SM7/32X32 L=15
16	25292	1	送り軸	FEED ROCK SHAFT
17	25282	1	送り腕	FEED DRIVING ROCK FRAME
18	25284	1	ピンねじ	FEED BAR HINGE PIN
19	25285	1	ナット	NUT
20	25317	1	締めねじ	PINCH SCREW SM9/32X28
21	25286	1	送り軸メタル(前)	FEED ROCK SHAFT BUSHING (FRONT)
22	25287	1	止めねじ	SET SCREW 17/64X32 L=14
23	25290	1	ライナー	LINER
24	25163	1	止めねじ	SET SCREW 17/64X32 L=11
25	25291	2	カラー	COLLAR
26	25156	4	止めねじ	SET SCREW SM1/4X32 L=4.5
27	25286	1	送り軸メタル(後)	FEED ROCK SHAFT BUSHING (BACK)
28	25170	1	止めねじ	SET SCREW 17/64X32 L=20
29	25290	1	ライナー	LINER
30	25163	1	止めねじ	SET SCREW 17/64X32 L=11
31	25279	1	送り土台	FEED BAR
32	12064	1	送り歯 5/64-3/32(標準)	FEED DOG 5/64-3/32 (STANDARD)
33	25318	1	フェルト	OIL FELT
34	25283	2	ゴム栓	RUBBER CAP
35	25511	1	送り板押え	FEED PLATE PRESSER
36	25512	1	止めねじ	SCREW SM11/64X40

下軸關係/Lower shaft mechanism

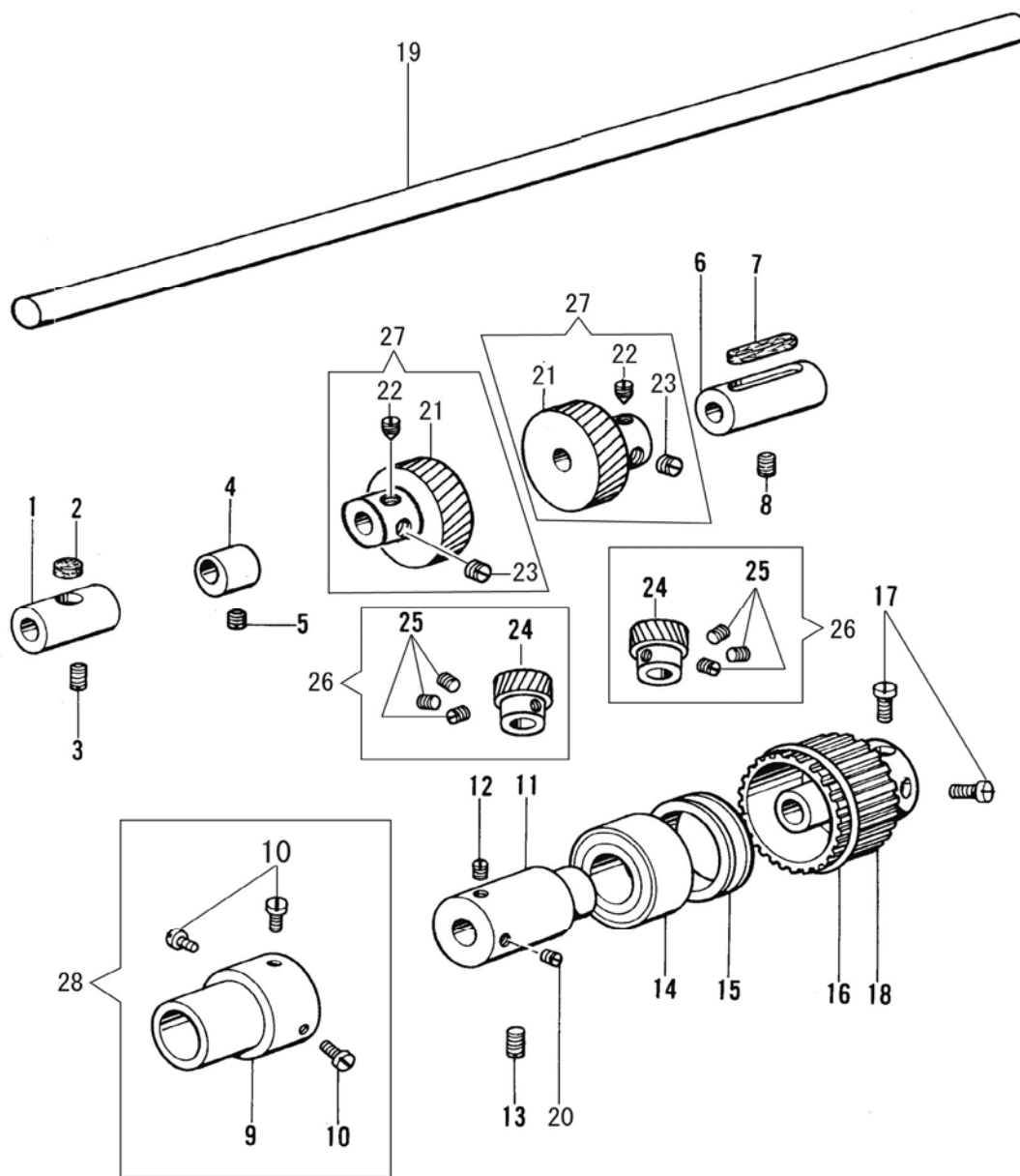

下軸関係/Hook driving shaft mechanism

No.	部品番号	数量	品名	PARTS NAME
	PARTS No.	QTY		
1	25235	1	下軸メタル(前)	HOOK DRIVING SHAFT BUSHING (FRONT)
2	25311	1	フェルト	FELT
3	25170	1	止めねじ	SET SCREW 17/64X32 L=20
4	25238	1	送り上下カム	FEED LIFTING ECCENTRIC
5	25156	1	止めねじ	SET SCREW SM1/4X32 L=4.5
6	25241	1	下軸メタル(中)	HOOK DRIVING SHAFT BUSHING (MIDDLE)
7	25242	1	油芯	OIL WICK
8	25170	1	止めねじ	SET SCREW 17/64X32 L=20
9	25623	1	下軸ベアリングケース	HOOK DRIVING SHAFT BEARING CASE
10	25661	3	止めねじ	SET SCREW 9/64X40 L=5
11	25252	1	下軸ベアリングカラー	HOOK DRIVING SHAFT BEARING COLLAR
12	25196	1	止めねじ	SET SCREW SM1/4X32 L=5.5
13	25170	1	止めねじ	SET SCREW 17/64X32 L=20
14	25254	1	ベアリング	BEARING
15	25255	1	溝付リング	RING
16	25191	1	プーリーリング	PULLEY RING
17	10612	2	止めねじ	SET SCREW SM1/4X32 L=10.5
18	25256	1	下軸ベルトプーリ	HOOK DRIVING SHAFT BELT PULLEY
19	25237	1	下軸	HOOK DRIVING SHAFT
20	25253	1	止めねじ	SET SCREW SM1/4X32 L=5.5
21	25239	2	大ギヤー	GEAR (LARGE)
22	25165	2	位置決めねじ	POSITION SCREW SM1/4X40 L=8
23	25240	2	止めねじ	SET SCREW SM1/4X40 L=7
24	25155	2	小ギヤー	GEAR (SMALL)
25	25156	6	止めねじ	SET SCREW SM1/4X40 L=4.5
26	25155C	1	小ギヤー・ねじ付き	GEAR (SMALL) WITH SCREW
27	25239C	1	大ギヤー・ねじ付き	GEAR (LARGE) WITH SCREW
28	25623C	1	下軸ベアリングケース(組)	HOOK DRIVING SHAFT BEARING CASE COMP.

糸調子関係/Thread tension

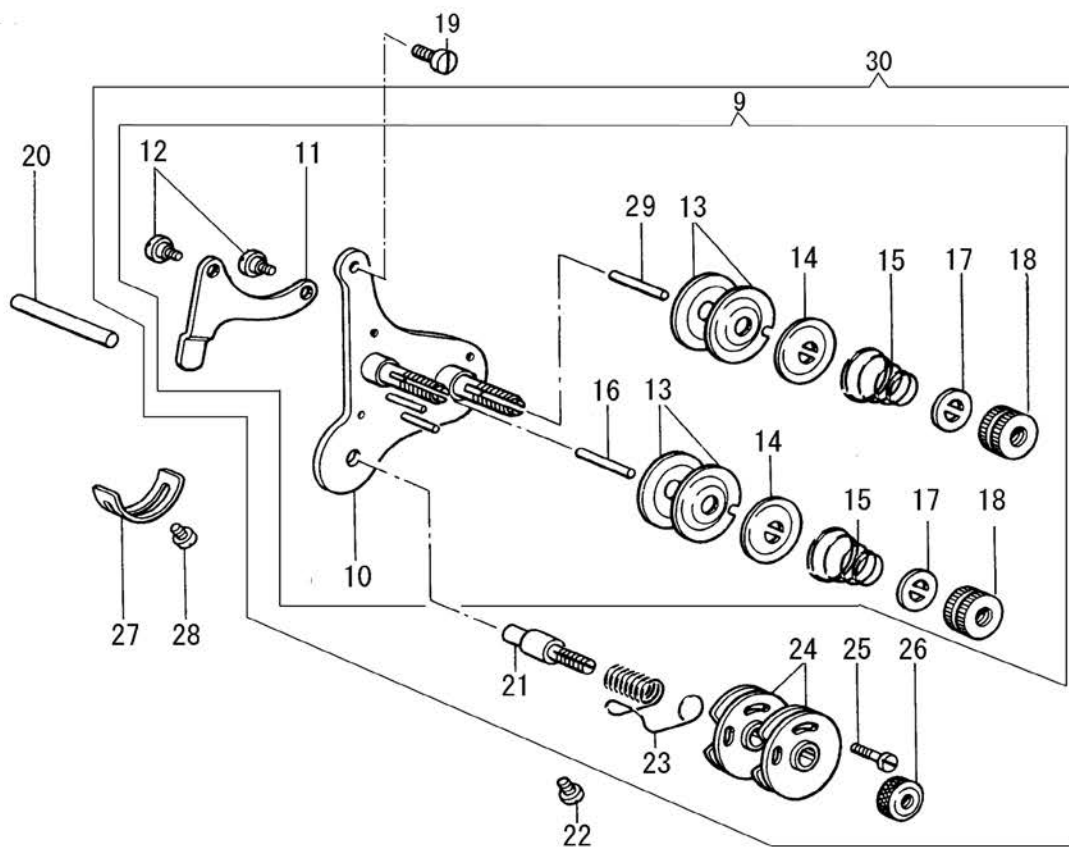
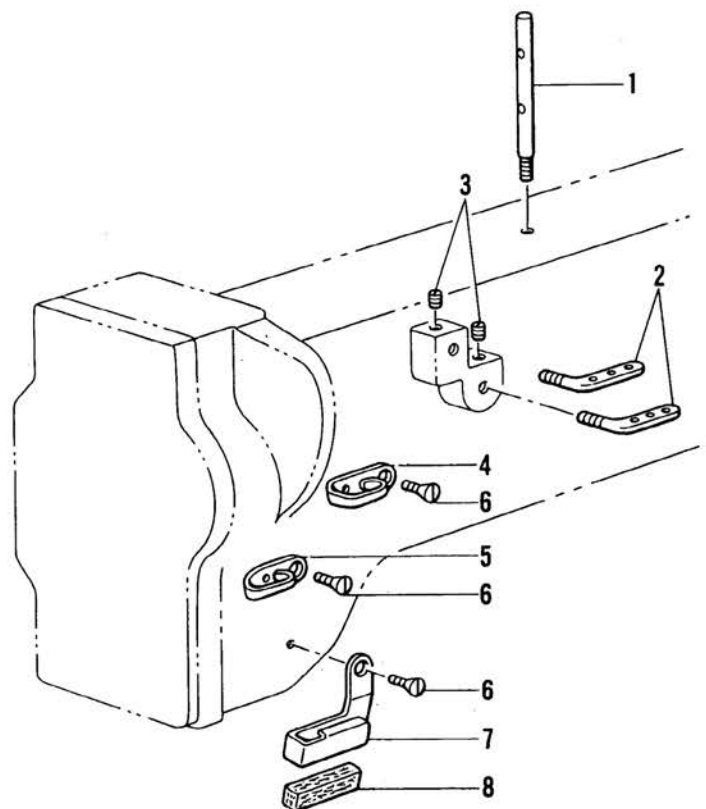

糸調子関係/Thread tension

No.	部品番号	数量	品名	PARTS NAME
	PARTS No.	QTY		
1	10942	1	糸掛け	THREAD GUIDE
2	25116	2	三つ穴糸掛け	THREAD RETAINER(3-HOLES)
3	25117	2	止めねじ	SET SCREW SM9/64X40 L=6.5
4	25118	1	面糸掛け(上)	ARM THREAD GUIDE (UPPER)
5	25509	1	面糸掛け(中)	ARM THREAD GUIDE (MIDDLE)
6	25119	3	止めねじ	SET SCREW SM9/64X40 L=6.5
7	10759-A	1	面糸掛け(下)	ARM THREAD GUIDE (LOWER)
8	10760	1	フェルト	FELT
9	10961C	1	調子板(組) ϕ 1.2	TENSION BRACKET COMPLETE, ϕ 1.2
10	10961	1	調子板	TENSION BRACKET
11	10678	1	糸緩め板	THREAD RELEASE PLATE
12	19422	2	段ねじ	HINGE SCREW SM9/64X40
13	19531	4	調子皿	TENSION DISC
14	19532	2	丸一皿	TENSION RELEASE WASHER
15	10693	2	渦巻きスプリング ϕ 1.2	TENSION SPRING, ϕ 1.2
16	10957	1	糸緩めピン(短)	TENSION RELEASING PLUNGER (SHORT)
17	28206	2	ローレットストッパー	THLIMB NUT WASHER
18	19513	2	ローレットナット	THUMB NUT
19	10561	1	止めねじ	SCREW SM11/64X32 L=6.5
20	10720	1	糸緩め軸	TENSION RELEASING SHAFT
21	10962	1	糸調子棒(長)	THREAD CONTROLLER STUD (LONG)
22	25128	1	止めねじ	SET SCREW SM11/64X40 L=14
23	10953	1	糸引きスプリング	THREAD CONTROLLER SPRING
24	10694	2	二重皿	THREAD CONTROLLER DISC
25	B144682	1	止めねじ	SCREW SM3/32X56 L=12.2
26	19534	1	ローレットナット	THREAD CONTROLLER STUD NUT
27	10690	1	スプリング受け	THREAD CONTROLLER SPRING STOP
28	8100	1	止めねじ	SCREW SM9/64X40 L=6
29	10952	1	糸緩めピン(長)	TENSION RELEASING PLUNGER (LONG)
30	10963C	1	調子板(大組) ϕ 1.2	TENSION BRACKET COMPLETE, ϕ 1.2

カマ・カマ土台関係/ Hook·Hook bracket mechanism

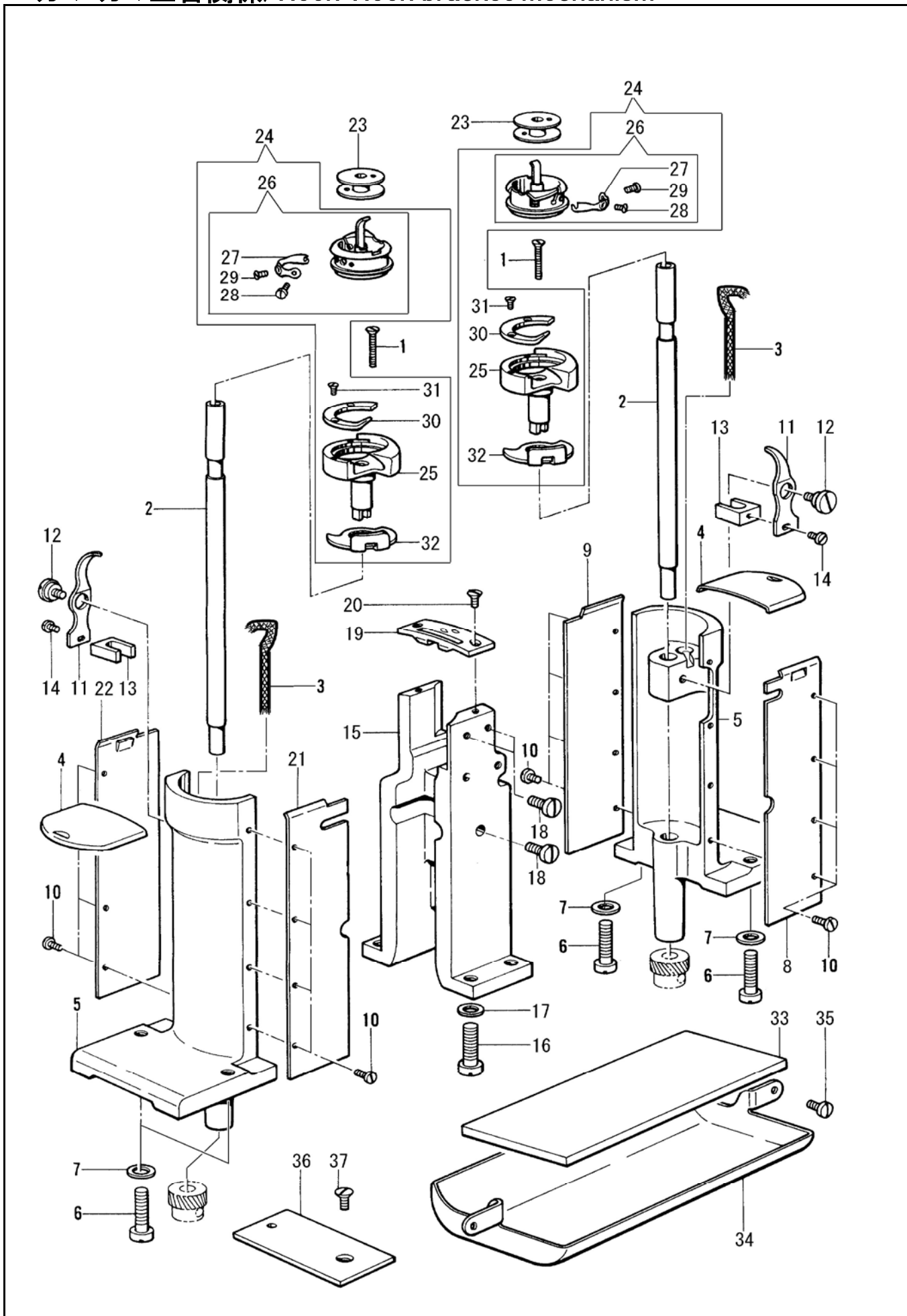

カマ・カマ土台関係/ Hook・Hook bracket mechanism

No.	部品番号	数量	品名	PARTS NAME
	PARTS No.	QTY		
1	25140	2	止めねじ	HOOK SET SCREW SM9/64X40 L=26
2	25152	2	カマ軸	HOOK DRIVING SHAFT
3	25310	2	油芯	OIL WICK
4	25141	2	カマぶた	HOOK COVER
5	25146	2	カマ土台・メタル(組)	HOOK BRACKET, BUSHING COMPLETE
6	25147	4	止めねじ	SCREW SM5/16X24 L=26
7	25148	4	座金	WASHER
8	25518	1	カマ土台カバー(右前)	HOOK BRACKET COVER (RIGHT FRONT)
9	25519	1	カマ土台カバー(右後)	HOOK BRACKET COVER (RIGHT BACK)
10	14013	16	止めねじ	SCREW SM9/64X40 L=5
11	25142	2	ボビンケース オープナー	BOBBIN CASE OPENER
12	25143	2	段ねじ	HINGE SCREW SM9/32X28 L=6
13	25144	2	オープナー二又	OPENER BRACKET
14	25145	2	止めねじ	SCREW SM9/64X40 L=6
15	25513	1	針板土台	THROAT PLATE BRACKET
16	61539	4	止めねじ	SCREW SM5/16X24 L=18
17	25148	4	座金	WASHER
18	25150	3	止めねじ	SCREW SM11/64X32 L=6
19	12062	1	針板 3/32"(標準)	THROAT PLATE 3/32"(STANDARD)
20	25136	2	止めねじ	SCREW SM9/64X40 L=8
21	25516	1	カマ土台カバー(左前)	HOOK BRACKET COVER (LEFT FRONT)
22	25517	1	カマ土台カバー(左後)	HOOK BRACKET COVER (LEFT BACK)
23	10656	2	ボビン	BOBBIN
24	12530	2	カマ(組)	HOOK COMPLETE
25	13086-01	2	外カマ	HOOK
26	11124-02	2	内カマ(組)	BOBBIN CASE COMPLETE
27	11124-10	2	調子ばね	BOBBIN CASE TENSION SPRING
28	16407-11	2	止めねじ	SCREW
29	11124-12	2	調節ねじ	REGULATING SCREW
30	16291-03	2	内カマ押え	HOOK GIBE
31	16407-04	4	止めねじ	SCREW
32	12032-05	2	針受け	HOOK NEEDLE GUARD
33	25125	1	フェルト	GEAR COVER FELT
34	25126	1	ギヤーカバー	GEAR COVER
35	25127	2	止めねじ	SCREW SM11/64X32 L=6.5
36	25520	1	差し板	COVER
37	25123	1	止めねじ	SCREW SM9/64X40 L=9

付属品関係/Accessories

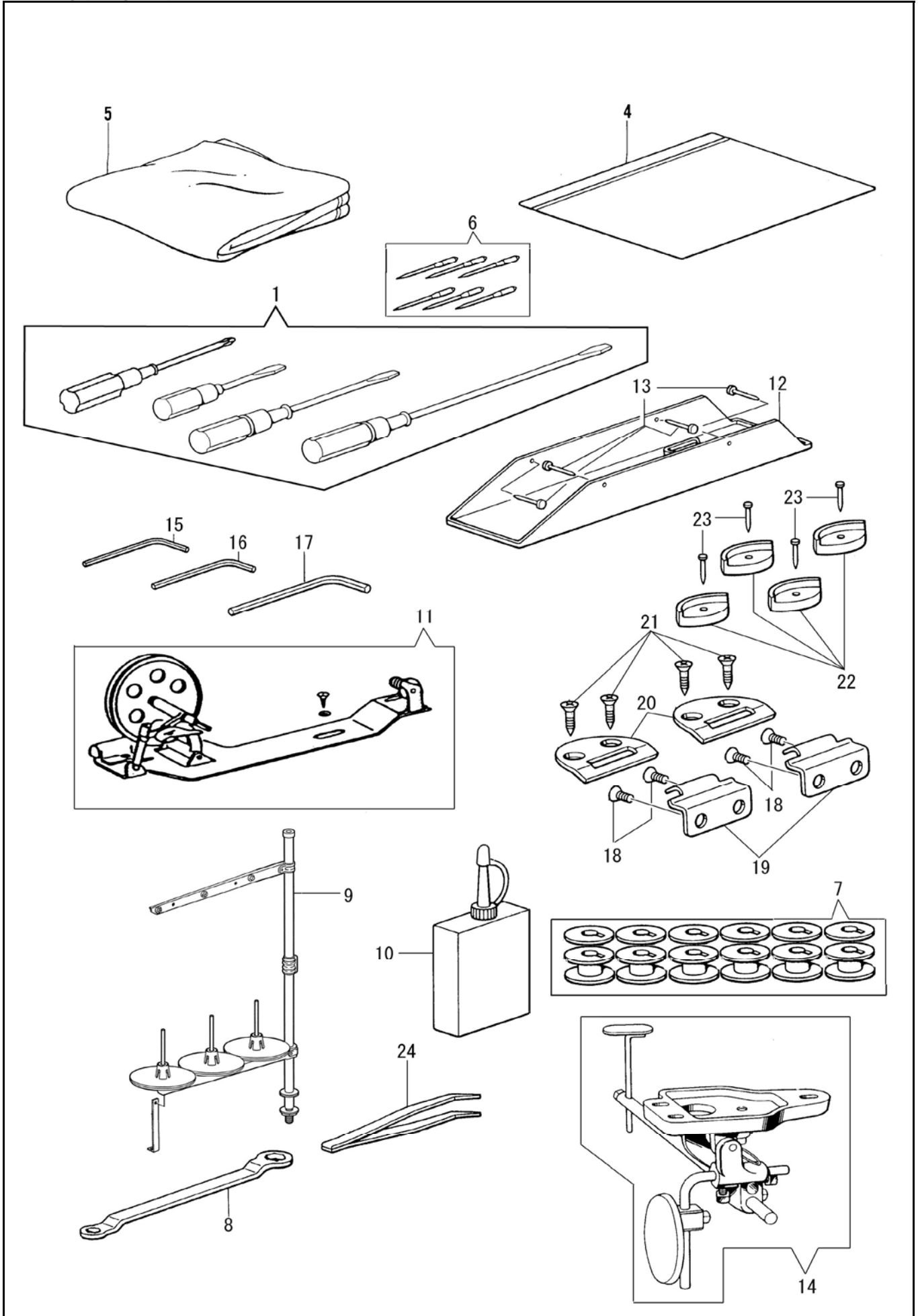

付属品関係/Accessories

No.	部品番号	数量	品名	PARTS NAME
	PARTS No.	QTY		
1	25649C	1	ドライバー(4点組)	SCREW DRIVER COMPLETE
4	8132-A	1	補用品袋	ACCESSORIES PACK
5	8124	1	ミシンカバー	MACHINE COVER
6	N1314	6	針 DP-F22 #14	NEEDLE DP-F22 #14
7	10656	12	ボビン	BOBBIN
8	19462	1	メガネレンチ	DOUBLE HEAD WRENCH
9	10947	1	糸立てセット	THREAD STAND
10	8123	1	油差し	OILIER
11	19465	1	糸巻きセット	BOBBIN WINDER COMPLETE
12	25293	1	油受	OIL PAN
13	6055	4	油受止め釘	OIL PAN NAIL
14	25298	1	膝上げセット	KNEE LIFTER COMPLETE
15	10747	1	六角レンチ(1/16")	WRENCH (1/16")
16	19457	1	六角レンチ(2.5mm)	WRENCH (2.5mm)
17	19458	1	六角レンチ(3mm)	WRENCH (3mm)
18	25307	4	ヒンジ止めねじ	BED HINGE SCREW 17/64X32
19	11171	2	ヒンジ受け	MACHINE HINGE CONNECTION PLATE
20	11169-B	2	ヒンジ	BED HINGE
21	6052	4	ヒンジ受け止め皿木ねじ	MACHINE HINGE COCCECTION PLATE WOOD SCREW
22	11887	4	コーナーゴム	TABLE CORNER RUBBER
23	6055	4	コーナーゴム止釘	NAIL
24	11196	1	ピンセット	PINCETTE

別売品/Option parts

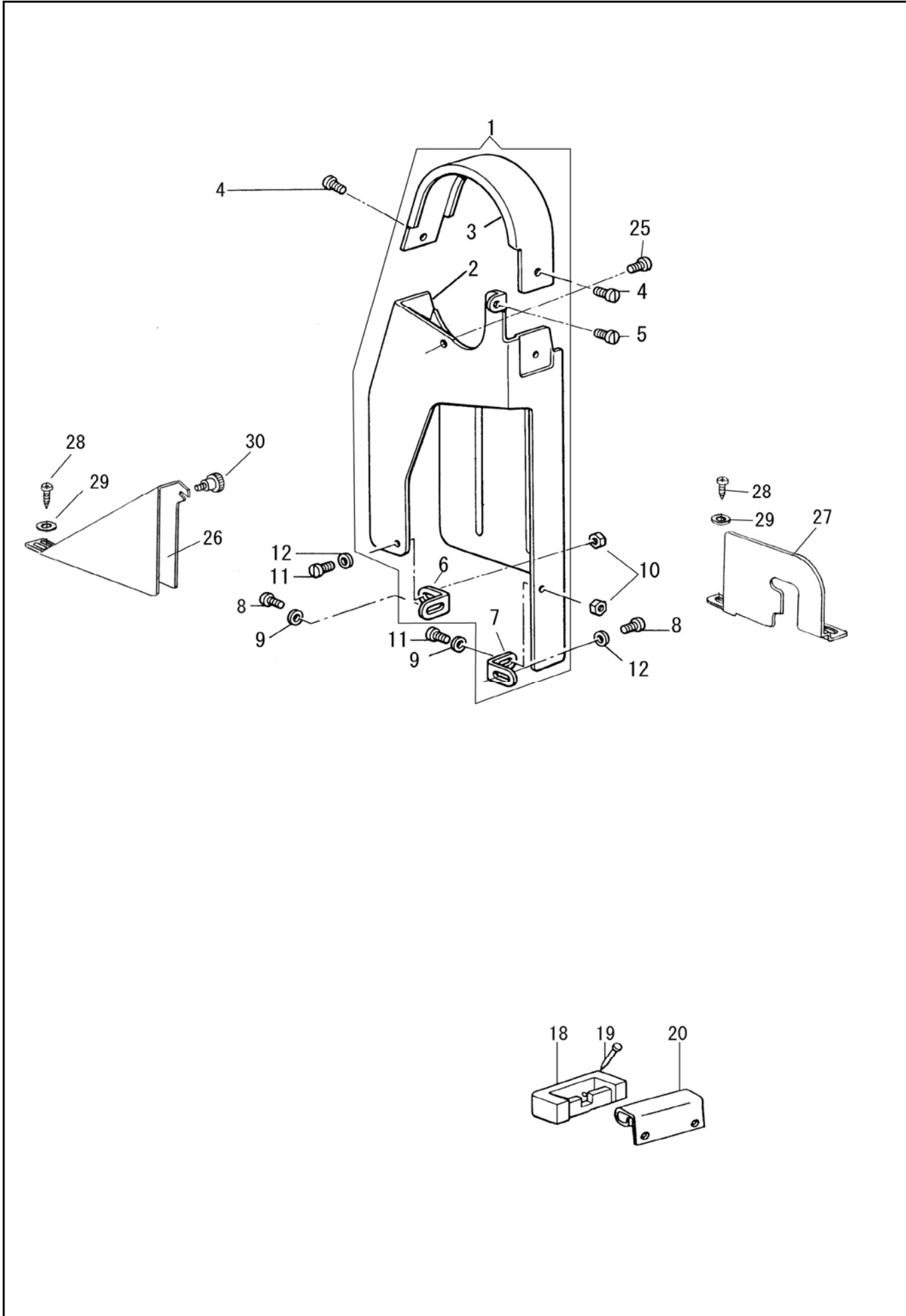





別売品/Option parts

No.	部品番号	数量	品名	PARTS NAME
	PARTS No.	QTY		
1	12294C	1	ベルトガード(組)	BELT GUARD COMPLETE
4	6339	2	止めねじ	SCREW SM1/8X44 L=4
5	18417	1	止めねじ	SCREW ϕ 4.5X32 L=8
6	12294-04	1	止め金具	STOPPER PLATE
7	13427	1	止め金具	STOPPER PLATE
8	14024	2	止めねじ	SCREW SM3/16X32
9	16287	2	座金	WASHER
10	50103	2	ナット	NUT
11	10561	2	止めねじ	SCREW SM11/64X32 L=6.5
12	11142	2	座金	WASHER
18	11886	2	ヒンジ受けゴム	MACHINE HINGE CONNECTION RUBBER
19	6055	2	ヒンジ受け止釘	NAIL
20	11169-A	2	ヒンジ	BED HINGE
25	11162	1	止めねじ	SCREW 3.4X36 L=5.4
26	12294-06	1	補助ガード	SUPPRT GUARD
27	12294-08	1	糸巻きカバー	THREAD WINDER COVER
28	15081	4	木ねじ	WOOD SCREW
29	11142	4	ワッシャー	WASHER
30	11830	1	補助ガード止めねじ	SCREW SM9/64X40





ゲージ表/Table of gauge parts

〈ローラー押え用/FOR ROLLER PRESSER FOOT〉

							
			針巾	針株	針板	送り歯	補助押え
GAUGE SIZE			NEEDLE CLAMP	THROAT PLATE	FEED DOG	SUB PRESSER FOOT	ROLLER HOLDER SPACER
Inch	mm						
3/64	1.2		12067	12058	12057	12521	12729
1/16	1.6			12060		12522	12738
5/64	2.0			12061	12064	12523	12730
3/32	2.4	*	11201-R	12062		15844	12731
		◎	14557-R	12063		12077	

* : 平行針用/FOR PARALLEL ◎ : STANDARD GAUGE

〈カマ土台カバー/ROTARY HOOK BRACKET COVER〉

							
			針巾	左前	左後	右前	右後
GAUGE SIZE			LEFT FRONT	LEFT BACK	RIGHT FRONT	RIGHT BACK	BED SLIDE COVER
Inch	mm						
3/64~ 3/32	1.2 ~ 2.4		25516	25517	25518	25519	25520

SEIKO SEWING MACHINE CO., LTD.

2-13-6 Sakaecho, Funabashi-shi Chiba Prefecture,
273-0018, Japan

TEL: 81-47-420-3561 (Overseas dept.)

FAX: 81-47-420-3560

E-mail: export@seiko-sewing.co.jp

<http://www.seiko-sewing.co.jp/>

セイコーミシン株式会社

〒273-0018 千葉県船橋市栄町2-13-6

TEL: 047-420-3561, IP電話: 050-3535-3491

FAX: 047-420-3560

E-mail: eigyo@seiko-sewing.co.jp

(国内営業)

Parts No. PB51210 (0921)

Rev. 2