

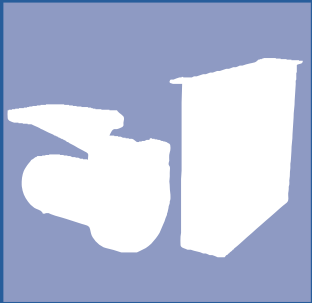

SEIKO®

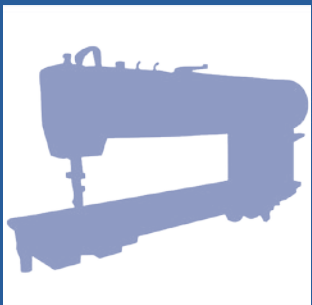
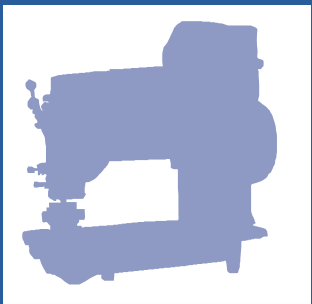
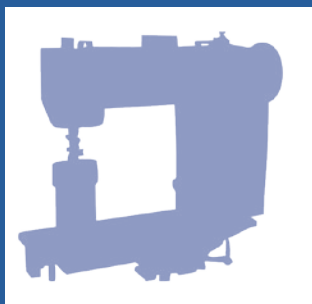
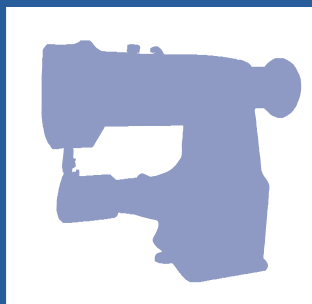

INDUSTRIAL SEWING MACHINE
FOR HEAVY DUTY
Since 1942

2016

INDUSTRIAL SEWING MACHINE CATALOG

Contents

Model code information

Model code information	2
------------------------------	---

Flat bed sewing machine

BBW series	3
BEW single needle series	7
BEW two needle series	11
H-2BL-AE-1	15
LSW single needle series (edge trimming)	17
LSW two needle series (angular stitch)	19
LSWN single needle series	21
LSWN two needle series	23
SK series	25
SLH series	27
SLH-2B-FH-1H	29
STH-8BLD-3	31
TH series	33
THM-26B-1-FL	35

Post bed sewing machine

BBWP series	37
LHPWN series	41
LPW-28BLK (angular stitch)	43
PW series	45

Cylinder bed sewing machine

CH series	47
CW series	49
LCW single needle serie	51
LCW two needle series	53
LSC series	55
TE / TF series	57

Zig-zag sewing machine

LZ2 series	59
SKZ series	61

Long arm sewing machine

BEW long arm series	63
JW series	65
LCW long arm series	67
LSWNH series	69
SK-2B-1-20	71

Double chain stitch sewing machine

LDA series	73
LD series	75
SSLD series	77

AC servo motor

HVP-i70	79
HVP-i90	81

*Speed depends on threads, materials and type of operation.

*Specification subject to change without notice.

BEW -28 BLCS-1-BTFL-CD-DS

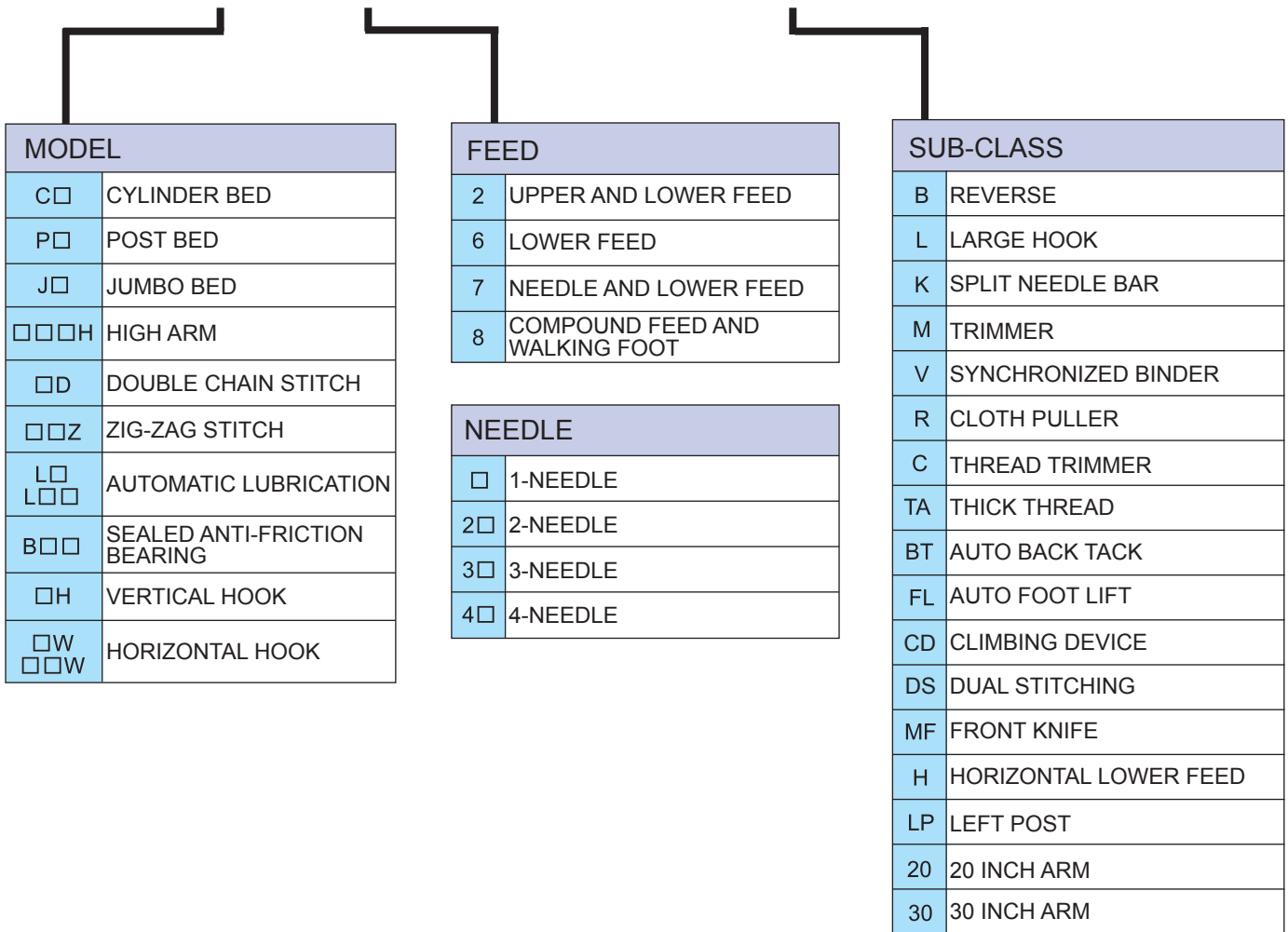

BBW series

High speed, Single needle, Compound feed and walking foot, Lockstitch sewing machine with automatic thread trimmer, Reverse stitch, Automatic backtacking, Automatic presser foot lift, Climbing device and dual stitching device



BBW-8BLC-BTFL-CD-DS

Variety

BBW-8BLC-BTFL-CD-DS

Applications

- For sewing medium to heavy weight materials such as leather, vinyl, synthetics and laminated and coated materials
- Suitable for sewing such as automobile upholstery tarpaulins, covers, awnings, tents, umbrellas handbags, luggage, travelware accessories, sports and camping equipment and wearing apparel outdoor clothing.



Features

- Longer stitch length quiet sewing operation
 - * Max. 9mm for both forward and reverse feed stitching.
 - * Compound feed and walking foot for positive stitching formation.
 - * Link-type thread take-up lever mechanism for high speed and quiet sewing operation.
- BBW series are equipped with a large vertical axis hook(1.6 times)
 - * Large capacity hook minimizes the time to replace the bobbin thread in stitching of thick thread.
 - * This hook promote highly efficient operation by reducing the frequency of bobbin thread replacement.
- Safety device
 - * Safety device prevents damage to hook and thread handling parts caused by thread jamming.
- Reliable thread trimming device
 - * Reliable automatic thread trimming device securely cuts up to #5 thread is equipped.
- One touch switchover for two different stitch lengths (DS device)
 - * Variety sewing materials such as steps, curves, uneven thickness can be performed by one touch switchover setting two different stitch lengths. The efficient work and beautiful finishes will be obtained.



1.6 times large capacity hook and reliable thread trimming device

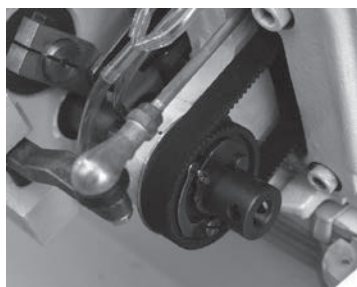

Safety device



One touch switchover for two different stitch lengths (DS Device)

- Built-in bobbin winder
 - * Built-in bobbin winder makes it possible to wind the bobbin thread during sewing operation.
- Wide working space
 - * 300 mm working space, from the needle to the sewing machine arm, makes sewing works easy to handle heavy weight and even large materials.
- Large clearance under presser foot
 - * The clearance under the presser foot (16mm), makes it easy to put heavy weight materials in and out.



Built-in bobbin winder



Wide working space

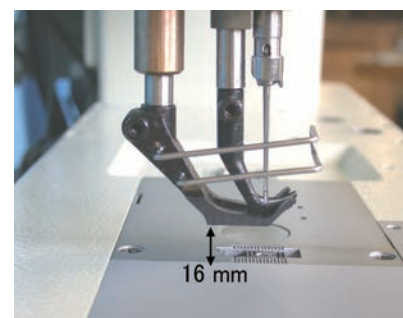

The clearance under the presser foot (16mm)

- Presser bar lifter
 - * As the presser bar lifter is located on the right side of the sewing machine, just above the reverse lever, sufficient space is kept behind the presser foot. Due to this, smooth sewing operation even rolled-up materials is guaranteed.



Presser bar lifter

BBW series

- Simple setting for alternating presser foot movement

- * Alternating presser foot movement between inner foot and outer foot can be changed simply by the easy-to-handle dial located at the top of the sewing machine.

- * Once the alternating movements have been set, the sewing speed is automatically controlled to the optimum speed so that stable sewing is maintained.

- Smooth stitching on step section (CD device)

- * The presser foot movement can be changed to maximum momentum (7mm) by button. Uneven thickness of materials can be smoothly performed changing the movement right before the uneven point.

- 5 operational switches improve working efficiency

- * 5 switch buttons are panelled on the convenient positions improve the efficient works.



Simple setting for alternating presser foot movement

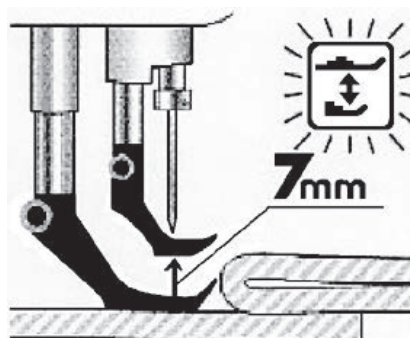

Smooth stitching on step section (CD device)



5 operational switches



Quick reverse switch

- * During Pressing the switch, sewing machine performs reverse stitching.



Walking foot movement change switch

- * By pressing the switch, the amount of walking foot movement is changed. When the indicating light is on, the movement is set at the maximum (7mm). When the indicating light is off, the movement is set by the walking foot movement dial.



Auto backtack select switch

- * In case of auto backtacking is set beforehand, by pressing the switch, the auto backtacking is released. In case of auto backtacking is not set, by pressing the switch, the auto backtacking performs. (Both are effective only at the first time.)



Half stitch switch

- * When sewing machine stops, the needle position can be changed by pressing the switch at up position or down position as desired.



Stitch length change switch

- * By pressing the switch, two different stitch lengths set beforehand can be changed one to the other. When the indicating light is on, the shorter stitch length is available, while the longer stitch is available when the light is off.

Specifications

Variety	BBW-8BLC-BTFL-CD-DS	
Number of needle	Single needle	
Max. sewing speed	3,500 s.p.m. (Refer to list below)	
Max.stitch length	9 mm	
Clearance under presser foot	by hand	9 mm
	by automatic foot lifter	16 mm
Needle bar stroke	34 mm	
Needle (Standard)	135 × 17 #110 - #200 (#160), DP × 17 #18 - #25 (#23)	
Thread	#30 - #5 (Standard #8)	
Hook	Large vertical axis hook (1.6 times)	
Thread length after trimming	27 mm	
Thread take up lever	Link type	
Amount of walking foot movement	1 - 7 mm	
Walking foot movement change switch	Dial type	
Bobbin winder	Built-in type located at the top of the sewing machine	
Auto presser foot lifting device	Pneumatic	
Walking foot movement change device	Pneumatic	
Safety device	Standard	
Lubrication	Automatic lubrication type	
Bed size / Working space	567 × 177 mm / 300 × 120 mm	
Net weight (Head only)	51 Kg	
Motor	AC Servo motor	

NOTE: (1) Speed depends on threads, materials and type of operation
 (2) Specifications subject to change without notice

Sewing speed range

Amount of walking foot movement	Stitch length	
	6 mm and less	6 mm ~ 9 mm
1 mm ~ 2 mm	3500 s.p.m	2000 s.p.m.
3 mm	3000 s.p.m.	
4 mm	2500 s.p.m.	
5 mm ~ 7 mm	2000 s.p.m.	

BBW-□

	8BLC-BTFL-CD-DS
Thread trimming (C)	○
Quick reverse feed (BT)	○
Auto presser foot lifting (FL)	○
Walking foot movement changeover (CD)	○
Stitch length change (DS)	○



SEIKO SEWING MACHINE CO., LTD.

2-13-6, Sakaecho, Funabashi-shi
 Chiba Prefecture, 273-0018, Japan

Phone : +81-47-420-3561 (Overseas dept.)

Fax : +81-47-420-3560

E-mail : export@seiko-sewing.co.jp

Printed in Japan 2016.04

<http://www.seiko-sewing.co.jp/>

BEW single needle series

High speed, Large vertical axis hook, Compound feed and walking foot, Reverse stitch, Lockstich machines

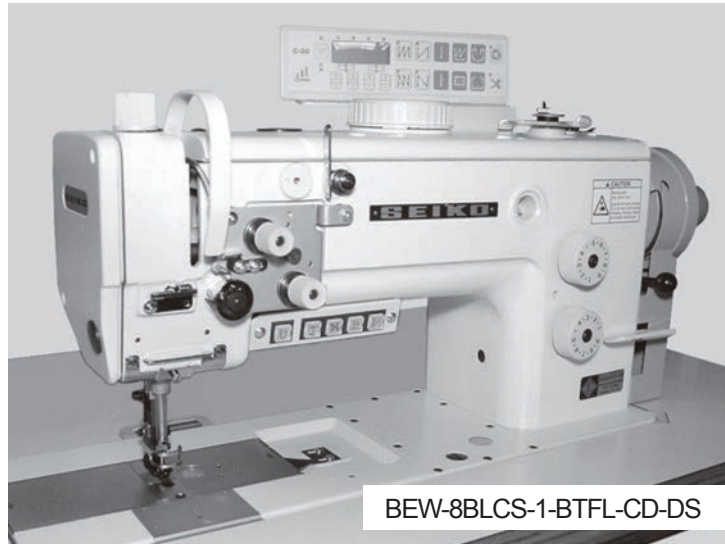

BEW-8BLS-1-BTFL-CD-DS

Variety

BEW-8BLS-1

S type presser foot

BEW-8BLS-1-BTFL-CD-DS

Thread trimmer, automatic back tack, automatic presser foot lift, climbing device, dual stitching device, S type presser foot

BEW-8BLE-1

E type presser foot

BEW-8BLE-1-BTFL-CD-DS

Thread trimmer, automatic back tack, automatic presser foot lift, climbing device, dual stitching device, E type presser foot

Applications

- For sewing medium to heavy weight materials such as leather, vinyl, synthetics and laminated and coated materials
- Suitable for sewing such as automobile upholstery, tarpaulins, covers, awnings, tents, umbrellas handbags, luggage, travelware accessories, sports and camping equipment and wearing apparel outdoor clothing.

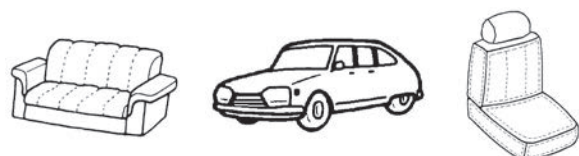

Features

- Longer stitch length quiet sewing operation
 - * Max. 9mm for both forward and reverse feed stitching.
 - * Compound feed and walking foot for positive stitching formation.
- BEW series are equipped with a large vertical axis hook(2.0 times)
 - * Large capacity hook minimizes the time to replace the bobbin thread in stitching of thick thread.
 - * This hook promote highly efficient operation by reducing the frequency of bobbin thread replacement.
- Reliable thread trimming device
 - * Reliable automatic thread trimming device securely cuts up to #1 thread is equipped.
- One touch switchover for two different stitch lengths (DS device)
 - * Variety sewing materials such as steps, curves, uneven thickness can be performed by one touch switchover setting two different stitch lengths. The efficient work and beautiful finishes will be obtained. (-DS type)

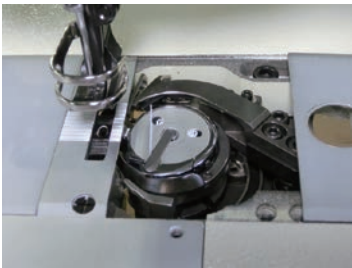

2.0 times large capacity hook, reliable thread trimming device

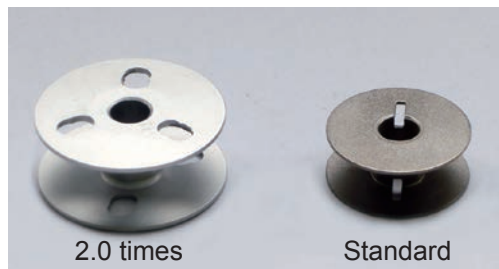

2.0 times Standard
Comparison of the bobbin size



One touch switchover for two different stitch lengths (DS Device)

- Built-in bobbin winder
 - * Built-in bobbin winder makes it possible to wind the bobbin thread during sewing operation.
- Wide working space
 - * 300 mm working space, from the needle to the sewing machine arm, makes sewing works easy to handle heavy weight and even large materials.
- Large clearance under presser foot
 - * The clearance under the presser foot (16mm), makes it easy to put heavy weight materials in and out.



Built-in bobbin winder



Wide working space

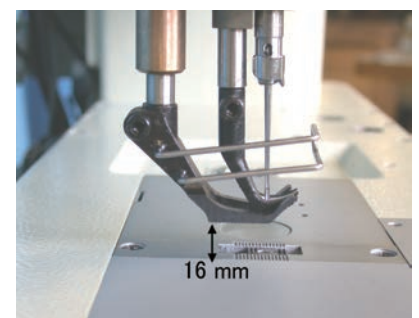

The clearance under the presser foot (16mm)

- Simple setting for walking foot movement
 - * Walking foot movement between inner foot and outer foot can be changed simply by the easy-to-handle dial located at the top of the sewing machine.
 - * Once the walking movements have been set, the sewing speed is automatically controlled to the optimum speed so that stable sewing is maintained.
- Smooth stitching on step section (CD device)
 - * The presser foot movement can be changed to maximum momentum (7mm) by button. Uneven thickness of materials can be smoothly performed changing the movement right before the uneven point.

BEW single needle series

- 5 operational switches improve working efficiency

- * 5 switch buttons panelled on the convenient positions improve the efficient works.



Simple setting for walking foot movement

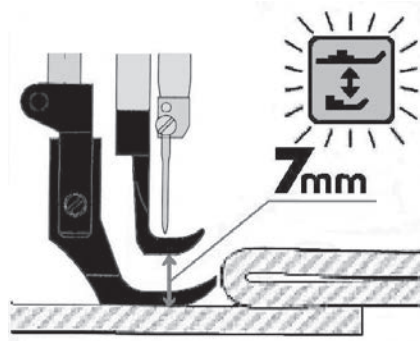

Smooth stitching on step section (CD device)



5 operational switches

- * Quick reverse switch
- * Walking foot movement change switch
- * Auto backtack select switch
- * Half stitch switch
- * Stitch length change switch

- Selectable two different type of presser foot for your preference.

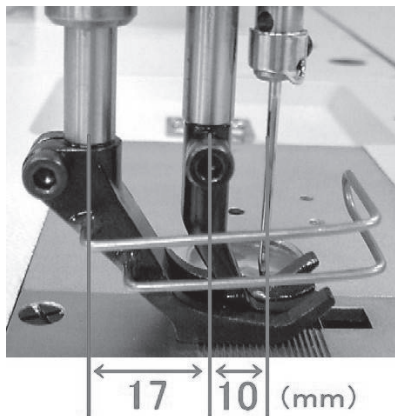

E type

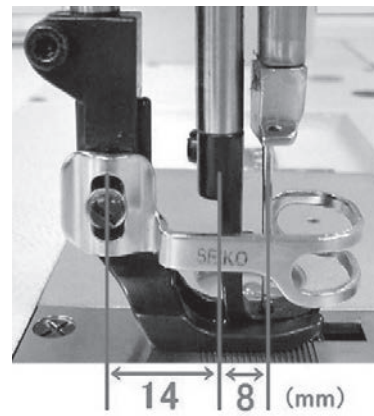

S type

- * E type presser foot is available as an option.

- Guide (optional parts)

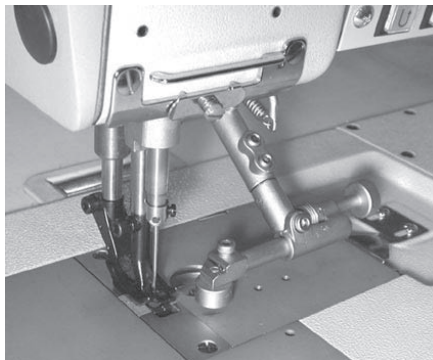

On duty

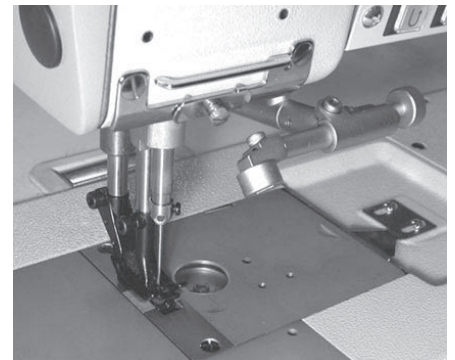

Off duty

BEW single needle series

Specifications (BEW-□)

Variety		8BLS-1	8B LCS-1-BTFL-CD-DS
Number of needle		Single needle	
Max. sewing speed		2,500 s.p.m. (Refer to list below)	
Max. stitch length		9 mm	
Clearance under presser foot	by hand	9 mm	
	by knee	16 mm	-
	by automatic foot lifter	-	16 mm
Needle bar stroke		37 mm	
Needle (Standard)		135×17 #110 - #200 (#160), DP×17 #18 - #25 (#23)	
Thread		#30 - #1 (Standard #5)	
Hook		Large vertical axis hook (2.0 times)	
Thread length after trimming		-	Approx. 13 mm
Thread take up lever		Slide type	
Amount of walking foot movement		1 - 6.5 mm	1 - 7 mm
Walking foot movement change switch		Dial type	
Bobbin winder		Built-in type located at the top of the sewing machine	
Auto presser foot lifting device		-	Pneumatic
Walking foot movement change device		-	Pneumatic
Safety device		Standard	
Lubrication		Automatic lubrication type	
Bed size / Working space		567 × 177 mm / 300 × 120 mm	
Net weight (Head only)		49 Kg	51 Kg
Motor		Clutch motor	AC Servo motor

NOTE : (1)Thick thread application is available by order.
 (2)Speed depends on threads, materials and type of operation.
 (3)Specifications subject to change without notice

Sewing speed range

Amount of walking foot movement	Stitch length	
	6 mm and less	6 mm ~ 9 mm
1 mm ~ 2 mm	2500 s.p.m.	2000 s.p.m.
3 mm	2400 s.p.m.	
4 mm	2300 s.p.m.	
5 mm ~ 7 mm	2000 s.p.m.	

BEW-□

	8B LCS-1-BTFL-CD-DS
Thread trimming (C)	○
Quick reverse feed (BT)	○
Auto presser foot lifting (FL)	○
Walking foot movement changeover (CD)	○
Stitch length change (DS)	○



SEIKO SEWING MACHINE CO., LTD.

2-13-6, Sakaecho, Funabashi-shi
 Chiba Prefecture, 273-0018, Japan

Phone : +81-47-420-3561 (Overseas dept.)

Fax : +81-47-420-3560

E-mail : export@seiko-sewing.co.jp

Printed in Japan 2016.04

<http://www.seiko-sewing.co.jp/>

BEW two needle series

High speed, Large vertical axis hook, Compound feed and walking foot, Reverse stitch, Lockstich machines

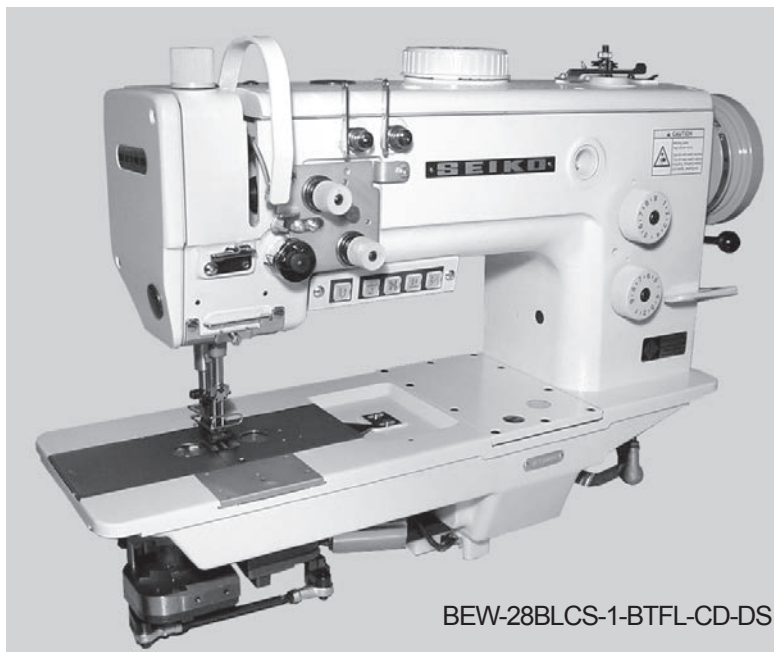

BEW-28BLS-1-BTFL-CD-DS

Variety

BEW-28BLS-1

BEW-28BLS-1-BTFL-CD-DS

Thread trimmer, automatic back tack, automatic presser foot lift, climbing device, dual stitching device

Applications

- For sewing medium to heavy weight materials such as leather, vinyl, synthetics and laminated and coated materials
- Suitable for sewing such as automobile upholstery, tarpaulins, covers, awnings, tents, umbrellas handbags, luggage, travelware accessories, sports and camping equipment and wearing apparel outdoor clothing.



Features

- Longer stitch length quiet sewing operation
 - * Max. 9mm for both forward and reverse feed stitching.
 - * Compound feed and walking foot for positive stitching formation.
- BEW series are equipped with a large vertical axis hook (2.0 times)
 - * Large capacity hook minimizes the time to replace the bobbin thread in stitching of thick thread.
 - * This hook promote highly efficient operation by reducing the frequency of bobbin thread replacement.
- Reliable thread trimming device
 - * Reliable automatic thread trimming device securely cuts up to #1 thread is equipped.
- One touch switchover for two different stitch lengths (DS device)
 - * Variety sewing materials such as steps, curves, uneven thickness can be performed by one touch switchover setting two different stitch lengths. The efficient work and beautiful finishes will be obtained. (-DS type)

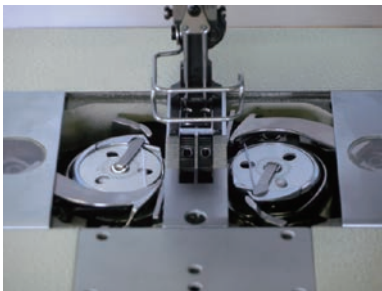

2.0 times large capacity hook, reliable thread trimming device

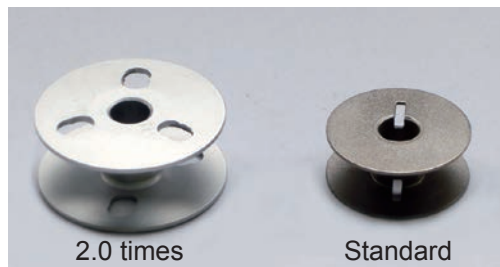

Comparison of the bobbin size



One touch switchover for two different stitch lengths (DS Device)

- Built-in bobbin winder
 - * Built-in bobbin winder makes it possible to wind the bobbin thread during sewing operation.
- Wide working space
 - * 300 mm working space, from the needle to the sewing machine arm, makes sewing works easy to handle heavy weight and even large materials.
- Large clearance under presser foot
 - * The clearance under the presser foot (16mm), makes it easy to put heavy weight materials in and out.



Built-in bobbin winder

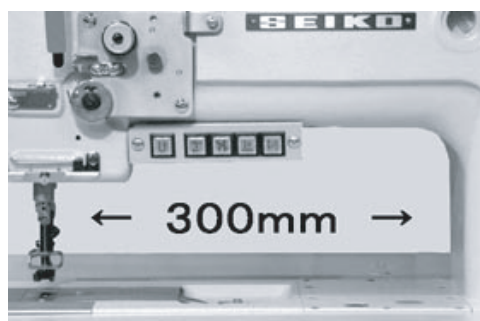

Wide working space

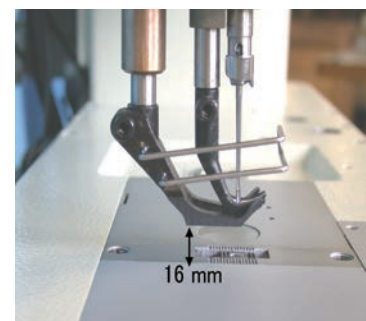

The clearance under the presser foot (16mm)

- Simple setting for walking foot movement
 - * Walking foot movement between inner foot and outer foot can be changed simply by the easy-to-handle dial located at the top of the sewing machine.
 - * Once the walking movements have been set, the sewing speed is automatically controlled to the optimum speed so that stable sewing is maintained.
- Smooth stitching on step section (CD device)
 - * The presser foot movement can be changed to maximum momentum (7mm) by button. Uneven thickness of materials can be smoothly performed changing the movement right before the uneven point.

BEW two needle series

- 5 operational switches improve working efficiency

- * 5 switch buttons are panelled on the convenient positions improve the efficient works.



Simple setting for walking foot movement

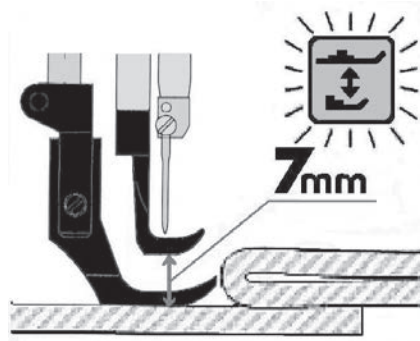

Smooth stitching on step section (CD device)



5 operational switches

- * Quick reverse switch
- * Walking foot movement change switch
- * Auto backtack select switch
- * Half stitch switch
- * Stitch length change switch

- Guide (optional parts)

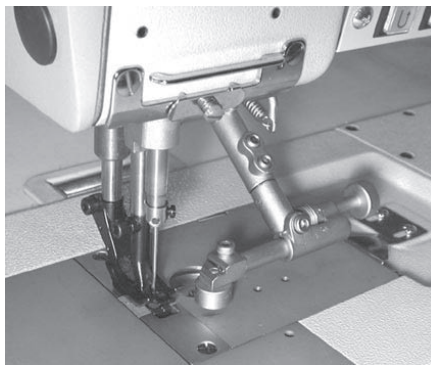

On duty

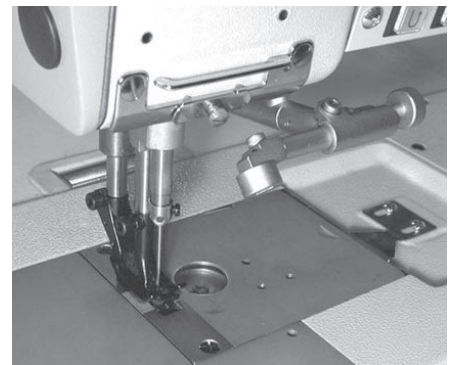

Off duty

BEW two needle series

Specifications (BEW-□)

Variety	28BLS-1	28BLCS-1-BTFL-CD-DS
Number of needle	Two needle	
Max. sewing speed	2,500 s.p.m. (Refer to list below)	
Max. stitch length	9 mm	
Clearance under presser foot	by hand	9 mm
	by knee	16 mm
	by automatic foot lifter	-
Needle bar stroke	37 mm	
Needle (Standard)	135 × 17 #110 - #200 (#160), DP × 17 #18 - #25 (#23)	
Thread	#30 - #1 (Standard #5)	
Hook	Large vertical axis hook (2.0 times)	
Thread length after trimming	-	Approx. 13 mm
Thread take up lever	Slide type	
Amount of walking foot movement	1 - 6.5 mm	1 - 7 mm
Walking foot movement change switch	Dial type	
Bobbin winder	Built-in type located at the top of the sewing machine	
Auto presser foot lifting device	-	Pneumatic
Walking foot movement change device	-	Pneumatic
Safety device	Standard	
Lubrication	Automatic lubrication type	
Bed size / Working space	567 × 177 mm / 300 × 120 mm	
Net weight (Head only)	49 Kg	51 Kg
Motor	Clutch motor	AC Servo motor

NOTE: (1)Thick thread application is available by order.
 (2)Speed depends on threads, materials and type of operation.
 (3)Specifications subject to change without notice.

Sewing speed range

Amount of walking foot movement	Stitch length	
	6 mm and less	6 mm ~ 9 mm
1 mm ~ 2 mm	2500 s.p.m.	2000 s.p.m.
3 mm	2400 s.p.m.	
4 mm	2300 s.p.m.	
5 mm ~ 7 mm	2000 s.p.m.	

BEW-□

	28BLCS-1-BTFL-CD-DS
Thread trimming (C)	○
Quick reverse feed (BT)	○
Auto presser foot lifting (FL)	○
Walking foot movement changeover (CD)	○
Stitch length change (DS)	○

Needle gauge list (BEW-□)

Variety	Needle gauge size
28BLS-1 28BLCS-1-BTFL-CD-DS	standard : 1/4"(6.4 mm), 5/16"(7.9 mm), 3/8"(9.5 mm), 1/2"(12.7 mm) special : 1/8"(3.2 mm), 3/16"(4.8 mm)



SEIKO SEWING MACHINE CO., LTD.

2-13-6, Sakaecho, Funabashi-shi
Chiba Prefecture, 273-0018, Japan

Phone : +81-47-420-3561 (Overseas dept.)

Fax : +81-47-420-3560

E-mail : export@seiko-sewing.co.jp

Printed in Japan 2016.04

<http://www.seiko-sewing.co.jp/>

H-2BL-AE-1

Single needle, Large horizontal axis hook, Drop feed and walking foot, Lockstitch machines



H-2BL-AE-1

Variety

H-2BL-AE-1

Applications

- For sewing medium to heavy weight materials such as fabrics, leather, vinyl, synthetics and laminated and coated products.
- Suitable for sewing such products as bags, automobile work, awnings, vinyl and leather goods etc.

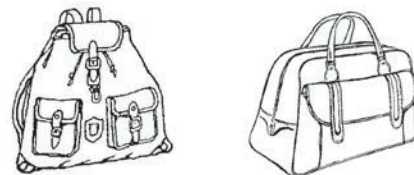

Features

- Full automatic lubrication system by pump.
- Large horizontal axis hook (2.0 times).
- Automatic lubricated hook.
- Feed regulating dial stopper assures uniform stitching.
- High presser foot lift.
- Easy adjustment of forward and reverse stitch length.

Specifications

Variety	H-2BL-AE-1	
Number of needle	Single needle	
Max. sewing speed	2000 s.p.m.	
Max.stitch length	5/16" (8 mm)	
Clearance under presser foot	by knee	5/8" (16 mm)
	by hand	5/16" (8 mm)
Needle bar stroke	1-29/64" (37 mm)	
Needle	DP x 17 (#23) , 135 x 17 (#160)	
Thread	#20 - #5 (Standard #8)	
Hook	Large horizontal axis hook (2.0 times)	
Amount of lift of walking foot	5/64"-3/16" standard 9/64" (2 - 5 mm) (standard 3.5 mm)	
Thread take up lever	Link type	
Lubrication	Automatic lubrication type (there is some exception)	
Bed size	18-45/64" x 7" (475 x 178 mm)	
Working space	10-15/64" x 4-23/32" (260 x 120 mm)	
Net weight(Head only)	29Kg	
Motor	Clutch motor	

NOTE: (1) Speed depends on threads, materials and type of operation
(2) Specifications subject to change without notice



SEIKO SEWING MACHINE CO., LTD.

2-13-6, Sakaecho, Funabashi-shi
Chiba Prefecture, 273-0018, Japan
Phone : +81-47-420-3561 (Overseas dept.)
Fax : +81-47-420-3560
E-mail : export@seiko-sewing.co.jp

Printed in Japan 2016.04

<http://www.seiko-sewing.co.jp/>

LSW single needle series (edge trimming)

High speed, Large vertical axis hook, Compound feed and walking foot, Reverse stitch, Lockstitch machines



LSW-8BLVMF

Variety

LSW-8BLVMF

Vertical edge trimming (front), synchronized binder(*)

LSW-8BLM

Vertical edge trimming(right)

(*)Available various special binder at extra charge



LSW-8BLVMF

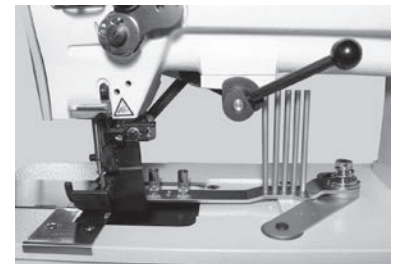

Applications

- For sewing medium to heavy weight fabrics, leather, vinyl, synthetics and laminated and coated materials
- Designed for operation such as tape binding, edge trimming for quilt, cushion, cover and automobile-interior.

* 8BLVMF Bedding, cover, carpet.

* 8BLM Heavy weight materials, automobile-interior and exterior decorations with trimming works.

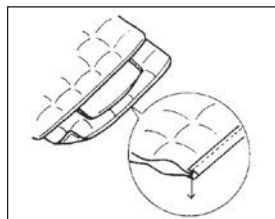

LSW-8BLVMF

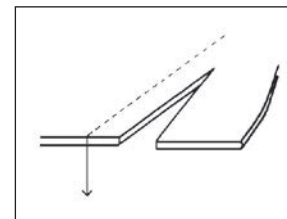

LSW-8BLM

LSW single needle series (edge trimming)

Features

- Seaming, tape binding and trimming can be performed by one operation.
- Large vertical axis hook. (Automatic hook lubrication)
- Safety clutch prevents the hook from being damaged.

•LSW-8BLVMF

Special binder can be supplied upon your request.

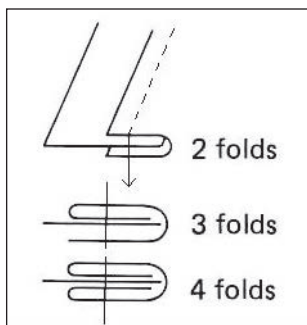

•LSW-8BLM

Sewing and Trimming can be performed by one operation



Suit for sewing and trimming simultaneous for leather, vinyl, heavy materials, automobile-interior, exterior decorations.

•LSW-8BLVMF

Trimming(front) and Taping can be performed by one operation.

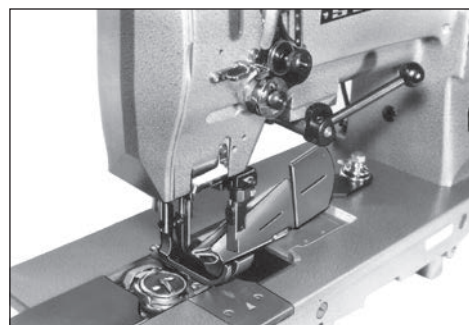

Suit for trimming and taping simultaneous for bedding, cover, cushion and carpet, etc. Trimming can be made in front of needle.

Specifications (LSW-□)

Variety	8BLVMF	8BLM
Number of needle	Single needle	
Max. sewing speed	2,500 s.p.m.	
Max. stitch length	1/4" (6.2 mm)	
Clearance under presser foot	by knee	15/32" (12 mm)
	by hand	21/64" (8.5 mm)
Needle bar stroke	1-5/16" (33.2 mm)	
Needle(standard)	MTx190 (#19) , 190R (#120)	DPx17 (#22) , 135x17 (#140)
Thread	#30 (standard)	#8 (standard)
Hook	Large vertical axis hook (2.0 times)	
Amount of lift of walking foot	1/8"-15/64" standard 5/32" (3 - 6 mm) (standard 4 mm)	
Standard binder spec (extra charge)	4-Fold Tape width 2-3/8"(60 mm)	-
Distance between seam and cutting edge	6 - 18 mm (standard 14 mm) 15/64"- 45/64" (standard 35/64")	4 , 5 , 6.5 , 8 , 10 mm (standard 8 mm) 5/16" - 25/64" (standard 5/16")
Thread take up lever	Slide type	
Lubrication	Semi-automatic lubrication type	
Bed size	20-25/64"x 7" (518 x 177 mm)	
Working space	10-5/32"x 3-35/64" (258 x 90 mm)	
Motor	Clutch motor	
Net weight(Head only)	34Kg	

NOTE: (1) Speed depends on threads, materials and type of operation (2) Specifications subject to change without notice



SEIKO SEWING MACHINE CO., LTD.

2-13-6, Sakaecho, Funabashi-shi
Chiba Prefecture, 273-0018, Japan

Phone : +81-47-420-3561 (Overseas dept.)

Fax : +81-47-420-3560

E-mail : export@seiko-sewing.co.jp

Printed in Japan 2016.04

<http://www.seiko-sewing.co.jp/>

LSW two needle series (angular stitch)

High speed, Large vertical axis hook, Compound feed and walking foot, Reverse stitch and split needle bar, Lockstitch machine



Variety

LSW-28BLK

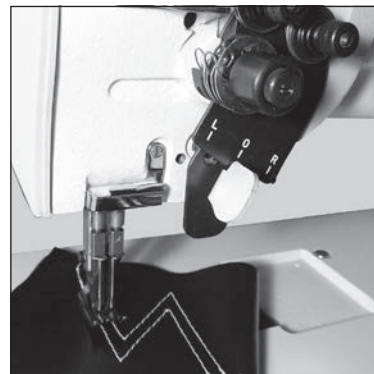

Angular stitching and/or straight stitching can be made by simplified operation

Applications

- For sewing medium to heavy materials such as leather, coats, jackets and jeans which require decorative or functional angular stitching.

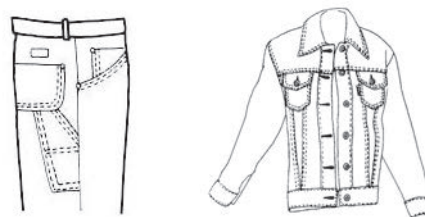

LSW two needle series (angular stitch)

Features

- Semi-automatic lubrication system.
- Large vertical axis hook (2.0 times).
- Automatic hook lubrication.
- Safety clutch prevents the hook from being damaged.
- Easy to operation of disengageable right and left needle bars by use of finger touch lever.

Specifications

Variety	LSW-28BLK	
Number of needle	Two needle	
Max. sewing speed	2,400 s.p.m.	
Max. stitch length	1/4" (6.5 mm)	
Clearance under presser foot	by knee	33/64" (13 mm)
	by hand	21/64" (8.5 mm)
Needle bar stroke	1-9/32" (32.6 mm)	
Needle(standard)	DPx17 (#22) , 135x17 (#140)	
Thread	#8 (standard)	
Hook	Large vertical axis hook (2.0 times)	
Amount of lift of walking foot	1/8"-15/64" standard 5/32" (3 - 6 mm) (standard 4 mm)	
Thread take up lever	Slide type	
Lubrication	Semi-automatic lubrication type	
Bed size	20-25/64"x 7" (518 x 177 mm)	
Working space	10-5/32"x 4-21/64" (258 x 110 mm)	
Motor	Clutch motor	
Net weight(Head only)	35Kg	

NOTE: (1) Speed depends on threads, materials and type of operation

(2) Specifications subject to change without notice

Needle gauge list

Variety	Needle gauge size
LSW-28BLK	Standard : 1/4"(6.4 mm), 5/16"(7.9mm), 3/8"(9.5mm)
	Special : 1/8"(3.2 mm), 3/16"(4.8mm)



SEIKO SEWING MACHINE CO., LTD.

2-13-6, Sakaecho, Funabashi-shi
Chiba Prefecture, 273-0018, Japan

Phone : +81-47-420-3561 (Overseas dept.)

Fax : +81-47-420-3560

E-mail : export@seiko-sewing.co.jp

Printed in Japan 2016.04

<http://www.seiko-sewing.co.jp/>

LSWN single needle series

High speed, Large vertical axis hook, Reverse stitch, Compound feed and walking foot, Lockstitch machines

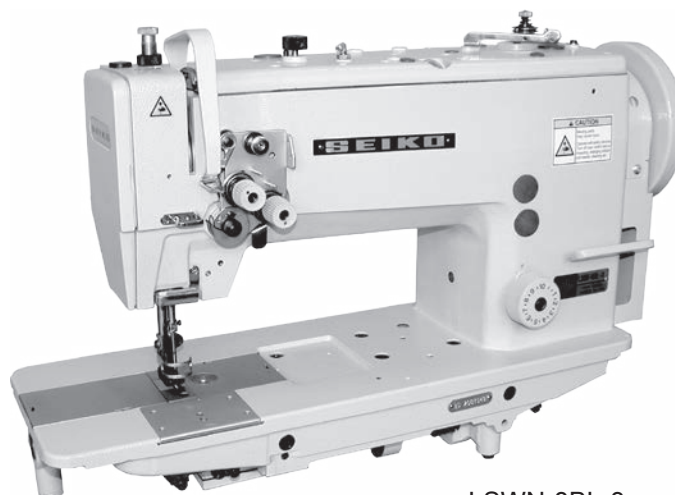

LSWN-8BL-3

Variety

LSWN-8BL-3

LSWN-8BL-3-TA

For thick thread

LSWN-8BLV-3

Synchronized binder

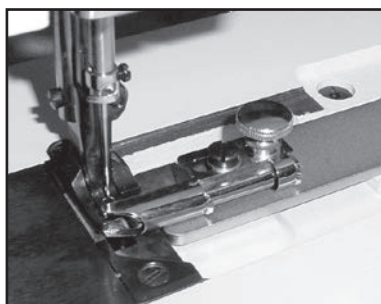

LSWN-8BLV-3

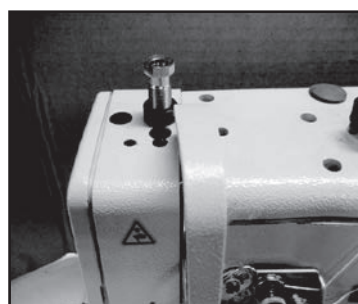

Pressure force can be adjusted simply and certainly with thumb screw at top.



Built-in bobbin winder that enables simple and fine adjustment of winding volume of threads

Applications

- For sewing medium to heavy weight fabrics, leather, vinyl, synthetics and laminated and coated materials.
- Suitable for sewing such as boat and furniture upholstery, tarpaulins, covers, awnings, tents, umbrellas, handbags, luggage, travelware accessories, sports and camping equipment, wearing apparel, outdoor clothing, footwear, foundation garments and orthopedic appliances.

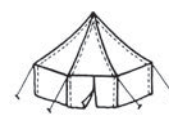

LSWN single needle series

Features

- Improved exposure of arm-feeding mechanism components which provides safety environment.(mechanical part of alternating presser foot, foot lifter mechanism(knee lifter) and presser foot spring relevant parts)
Plain needle drop area/adoption of open/close simplified face plate which provides wide-ranged movement of sewn material.
- Adoption of feed-adjusting dial which eases determination process of stitch length.
- Advanced penetration required for sewing of thick material/adoption of large pulley(O.D. 150mm) which enables the needle bar to be positioned properly.
- Built-in bobbin winder makes it possible to wind the bobbin thread during sewing operation.
- Elongated work space/adoption of built-in bobbin winder which no longer require mounting process.
- Adoption of die-casting oil pan of which by-knee-lifter is built-in, aiming at efficient installment
- Standard equipment of long stitch (max.10mm) suitable for thick material and amount of alternative presser lift (max. 6mm)
(LSWN-8BL-3, LSWn-8BL-3-TA)
- Large vertical axis hook (Automatic hook lubrication).
- Safety clutch prevents the hook from being damaged.



Single needle

Specifications (LSWN-□)

Variety	8BL-3	8BL-3-TA	8BLV-3
Number of needle	Single needle		
Max. sewing speed	2,800 s.p.m.		2,500 s.p.m.
Max. stitch length	25/64" (10 mm)		1/4" (6.2 mm)
Clearance under presser foot	by knee	5/8" (16 mm)	15/32" (12 mm)
	by hand	21/64" (8.5 mm)	
Needle bar stroke	1-5/16" (33.2 mm)		
Needle(standard)	DPx17(#22), 135x17(#140)	DPx17(#24), 135x17(#180)	DPx17(#18), 135x17(#110)
Thread	#8 (standard)	#5 (standard)	#8 (standard)
Hook	Large vertical axis hook (2.0 times)		
Amount of lift of walking foot	1/8"-15/64" standard 5/32" (3 - 6 mm) (standard 4 mm)		
Thread take up lever	Slide type		
Lubrication	Semi-automatic lubrication type		
Bed size	20-25/64"x 7" (518 x 177 mm)		
Working space	10-5/32"x 4-21/64" (258 x 110 mm)		
Motor	Clutch motor		
Net weight(Head only)	42.5 Kg		44.5 Kg

NOTE: (1) Speed depends on threads, materials and type of operation
(2) Specifications subject to change without notice



SEIKO SEWING MACHINE CO., LTD.

2-13-6, Sakaecho, Funabashi-shi
Chiba Prefecture, 273-0018, Japan

Phone : +81-47-420-3561 (Overseas dept.)

Fax : +81-47-420-3560

E-mail : export@seiko-sewing.co.jp

Printed in Japan 2016.04

<http://www.seiko-sewing.co.jp/>

LSWN two needle series

High speed, Large vertical axis hook, Reverse stitch, Compound feed and walking foot, Lockstitch machine

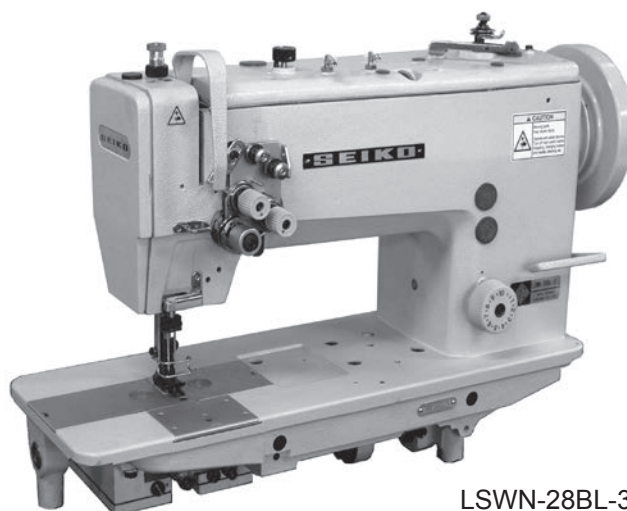

LSWN-28BL-3

Variety

LSWN-28BL-3

LSWN-28BL-3-TA

For thick thread

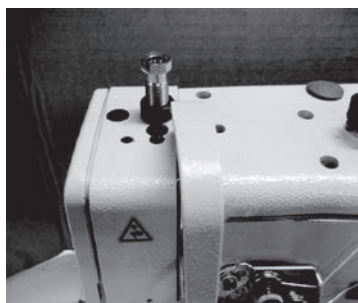

Pressure force can be adjusted simply and certainly with thumb screw at top.



Built-in bobbin winder that enables simple and fine adjustment of winding volume of threads

Applications

- For sewing medium to heavy weight fabrics, leather, vinyl, synthetics and laminated and coated materials.
- Suitable for sewing such as boat and furniture upholstery, tarpaulins, covers, awnings, tents, umbrellas, handbags, luggage, travelware accessories, sports and camping equipment, wearing apparel, outdoor clothing, footwear, foundation garments and orthopedic appliances.



LSWN two needle series

Features

- Improved exposure of arm-feeding mechanism components which provides safety environment.(mechanical part of alternating presser foot, foot lifter mechanism(knee lifter) and presser foot spring relevant parts)
Plain needle drop area/adoption of open/close simplified face plate which provides wide-ranged movement of sewn material.
- Adoption of feed-adjusting dial which eases determination process of stitch length.
- Advanced penetration required for sewing of thick material/adoption of large pulley(O.D. 150mm) which enables the needle bar to be positioned properly.
- Built-in bobbin winder makes it possible to wind the bobbin thread during sewing operation.
- Elongated work space/adoption of built-in bobbin winder which no longer require mounting process.
- Adoption of die-casting oil pan of which by-knee-lifter is built-in, aiming at efficient installment.
- Standard equipment of long stitch (max.10mm) suitable for thick material and amount of alternative presser lift (max. 6mm)
- Large vertical axis hook (Automatic hook lubrication).
- Safety clutch prevents the hook from being damaged.

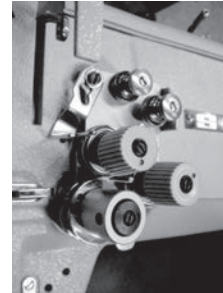

Two needle

Specifications (LSWN-□)

Variety	28BL-3	28BL-3-TA
Number of needle	Two needle	
Max. sewing speed	2,600 s.p.m.	
Max. stitch length	25/64" (10 mm)	
Clearance under presser foot	by knee	33/64" (13 mm)
	by hand	21/64" (8.5 mm)
Needle bar stroke	1-5/16" (33.2 mm)	
Needle(standard)	DPx17 (#22) , 135x17 (#140)	DPx17 (#24) , 135x17 (#180)
Thread	#8 (standard)	#5 (standard)
Hook	Large vertical axis hook (2.0 times)	
Amount of lift of walking foot	1/8"-15/64" (3 - 6 mm)	standard 5/32" (standard 4 mm)
Thread take up lever	Slide type	
Lubrication	Semi-automatic lubrication type	
Bed size	20-25/64"x 7" (518 x 177 mm)	
Working space	10-5/32"x 4-21/64" (258 x 110 mm)	
Motor	Clutch motor	
Net weight(Head only)	45 Kg	

NOTE: (1) Speed depends on threads, materials and type of operation
(2) Specifications subject to change without notice

Needle gauge list (LSWN-□)

Variety	Needle gauge size
28BL-3	standard : 1/4"(6.4 mm), 5/16"(7.9 mm), 3/8"(9.5 mm), 1/2"(12.7 mm), 3/4"(19 mm) special : 1/8"(3.2 mm), 3/16"(4.8 mm), 5/8"(15.9 mm), 1"(25.4 mm), 1-1/4"(31.8 mm), 1-1/2"(38.1 mm)
28BL-3-TA	standard : 3/8"(9.5 mm) special : 1/4"(6.4 mm), 5/16"(7.9 mm), 1/2"(12.7 mm), 3/4"(19 mm)



SEIKO SEWING MACHINE CO., LTD.

2-13-6, Sakaecho, Funabashi-shi
Chiba Prefecture, 273-0018, Japan

Phone : +81-47-420-3561 (Overseas dept.)

Fax : +81-47-420-3560

E-mail : export@seiko-sewing.co.jp

Printed in Japan 2016.04

<http://www.seiko-sewing.co.jp/>

SK series

Single needle, Extra heavy duty, Large horizontal axis hook, Drop feed and walking foot, Reverse stitch, Lockstitch machines

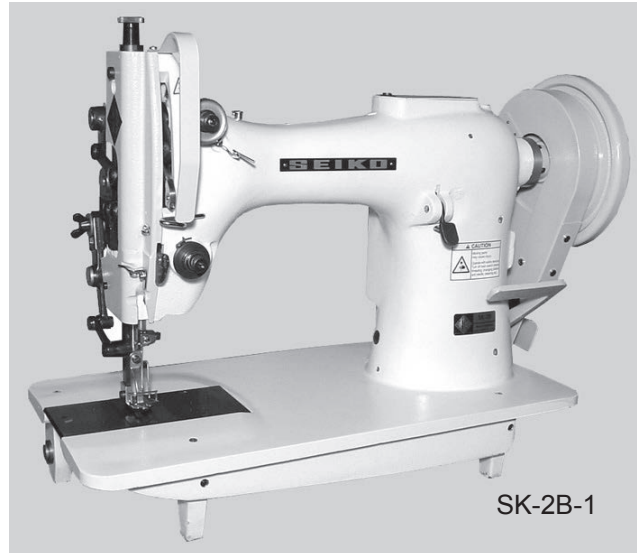

Variety

SK-2B-1

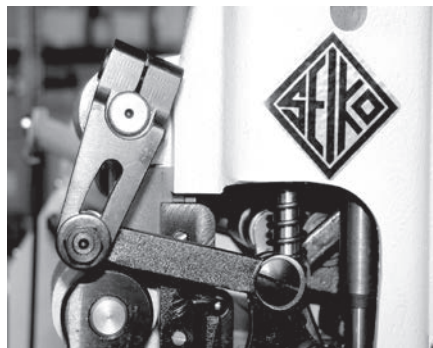

Alternating presser foot lift relative parts

Applications

- For sewing heavy weight leather, canvas, vinyl, and various coated and laminated fabrics
- Suitable for sewing such products as harnesses, covers, safety belts, tents, sheets, gloves, buffs, and heavy duty travel bags.

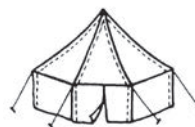

Features

- Horizontal axis rotary hook with extra large capacity bobbin
- Reverse stitching
- Extra large needle
- 20 inch long arm version available (Add "20" when ordering)

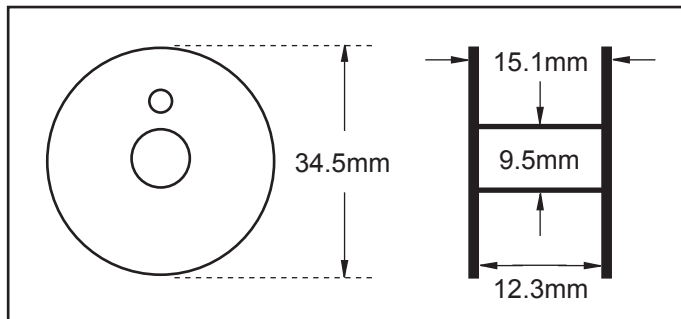

Large bobbin

Specifications

Variety	SK-2B-1	
Number of needle	Single needle	
Max. sewing speed	1,200 s.p.m.	
Max. stitch length	1/2" (13 mm)	
Clearance under presser foot	by pedal	35/64" (14 mm)
	by hand	1/2" (13 mm)
Needle bar stroke	2" (50.8 mm)	
Needle(standard)	DDx1 (#24) , 328 (#180)	
Thread	#0 - #5 (standard #5)	
Hook	Large horizontal axis hook	
Amount of lift of presser foot	1/8"-15/64" (3 - 6 mm)	standard 5/32" (standard 4mm)
Thread take up lever	Link type	
Lubrication	Hand type	
Bed size	20-15/32" x 9-27/32" (520 x 250 mm)	
Working space	10"x 7-31/64" (253 x 190 mm)	
Motor	Clutch motor	
Net weight(Head only)	44Kg	

NOTE: (1) Speed depends on threads, materials and type of operation
 (2) Specifications subject to change without notice



SEIKO SEWING MACHINE CO., LTD.

2-13-6, Sakaecho, Funabashi-shi
 Chiba Prefecture, 273-0018, Japan

Phone : +81-47-420-3561 (Overseas dept.)

Fax : +81-47-420-3560

E-mail : export@seiko-sewing.co.jp

Printed in Japan 2016.04

<http://www.seiko-sewing.co.jp/>

SLH series

Single needle, Long arm, Extra heavy duty, Large oscillating shuttle hook, Drop feed and walking foot, Reverse stitch, Lockstitch machines

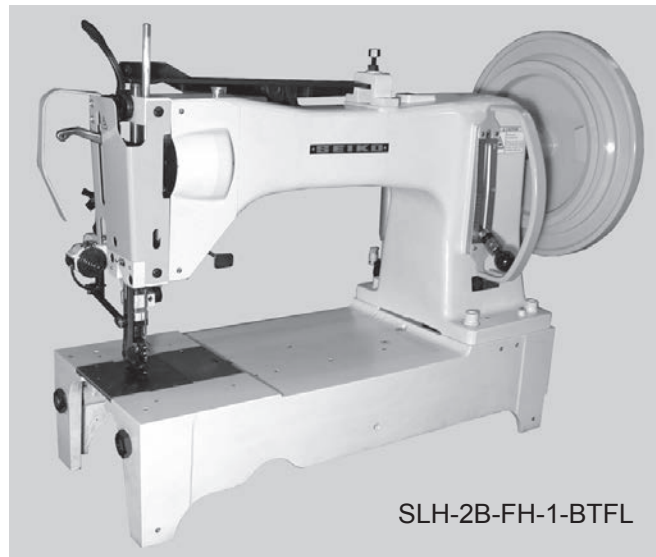

Variety

SLH-2B

SLH-2B-FH-1

Long needle bar stroke, high presser foot lift 32 mm

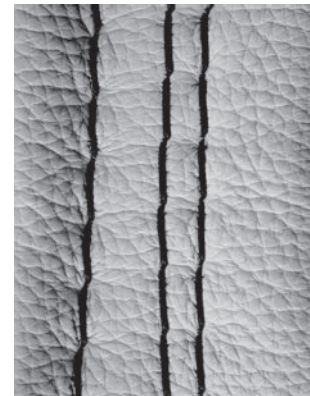

Applications

- For sewing extra heavy weight materials
- Suitable for sewing products such as safety and logging belts, cargo slings, buffing wheels, harnesses, construction barriers, parachutes, balloons and book binding.

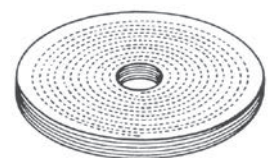

Features

- Suitable for extra thick thread (#0 - #00)
- Cam take-up type makes good tension.
- Synchronized walking foot and drop feeding mechanism assures uniform stitching.
- Extra high presser foot lift (32mm by pedal) enable sewing extra heavy materials (SLH-2B-FH-1).
- Extra large capacity hook minimizes the time to replace the bobbin thread.
- 413mm working space (Extra long arm), from the needle to the sewing machine arm, makes sewing works easy to handle heavy weight and even large materials.
- Long stitch length (15mm max.).
- Reverse stitching by stitch adjusting lever.
- Automatic back tack (BT) and automatic presser foot lift (FL) are available as option.

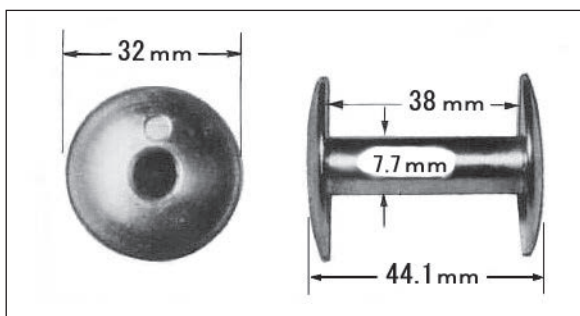

Large bobbin

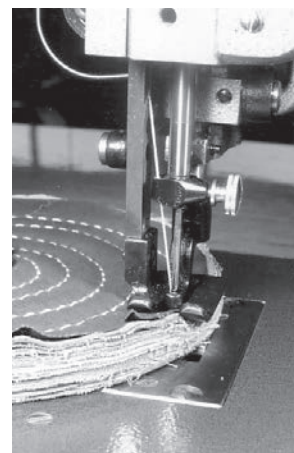

Buffing wheels

Specifications (SLH-□)

Variety		2B	2B-FH-1
Number of needle		Single needle	
Max. sewing speed		700 s.p.m.	
Max. stitch length		19/32" (15 mm)	
Clearance under presser foot	by pedal	1-7/64" (28 mm)	1-17/64" (32 mm)
	by hand	29/32" (23 mm)	1-9/64" (29 mm)
Needle bar stroke		2-15/64" (56.7 mm)	2-19/32" (66 mm)
Needle(standard)		Schmetz 1000 (#250)	
Thread		#0 (standard) - #00	
Hook		Large shuttle hook	
Amount of lift of alternating presser foot		3/16"-9/32" standard 15/64" (5 - 7 mm) (standard 6 mm)	
Thread take up lever		Cam type	
Lubrication		Hand type	
Bed size		25-3/4" x 10-5/32" (654 x 258 mm)	
Working space		16-1/4"x 8-37/64" (413 x 218 mm)	
Motor		Clutch motor	
Net weight(Head only)		105kg	

NOTE: (1) Speed depends on threads, materials and type of operation
(2) Specifications subject to change without notice



SEIKO SEWING MACHINE CO., LTD.

2-13-6, Sakaecho, Funabashi-shi
Chiba Prefecture, 273-0018, Japan
Phone : +81-47-420-3561 (Overseas dept.)
Fax : +81-47-420-3560
E-mail : export@seiko-sewing.co.jp

Printed in Japan 2016.04

<http://www.seiko-sewing.co.jp/>

SLH-2B-FH-1H

Single needle, Long arm, Super heavy duty, High foot lift,
Large oscillating shuttle hook, Drop feed and walking foot,
Reverse stitch, Lockstitch machine



SLH-2B-FH-1H

Variety

SLH-2B-FH-1H

High presser foot lift 40mm,
long needle bar stroke

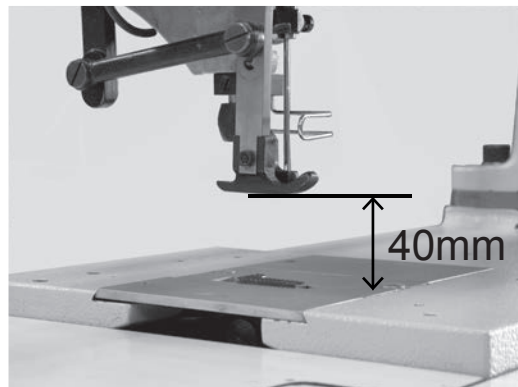

Applications

- For sewing super heavy weight materials.
- Suitable for sewing products such as safety and logging belts, cargo slings, buffing wheels, harnesses, construction barriers, parachutes, balloons and book binding.

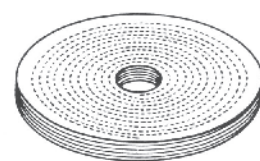
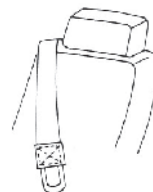
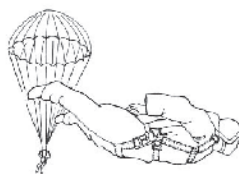

Features

- Suitable for extra thick thread (#00)
- Cam take-up type makes good tension.
- Synchronized walking foot and drop feeding mechanism assures uniform stitching.
- Extra high presser foot lift (40mm) enable sewing extra heavy materials. Due to functional specification, there is 13mm clearance between the presser foot and the throat plate when the presser foot comes to lowest position.
- Extra large capacity hook minimizes the time to replace the bobbin thread.
- 413mm working space (Extra long arm), from the needle to the sewing machine arm, makes sewing works easy to handle heavy weight and even large materials.
- Long stitch length (15mm max.).
- Reverse stitching by stitch adjusting lever.
- Automatic back tack (BT) and automatic presser foot lift (FL) are available as option.
- Needle with long blade (1001H #28) is suitable for sewing extra heavy weight materials.
- Optional gauge parts are available at extra cost to accommodate needle type 1000.

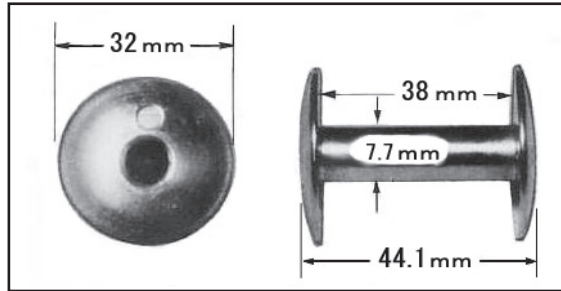

Large bobbin

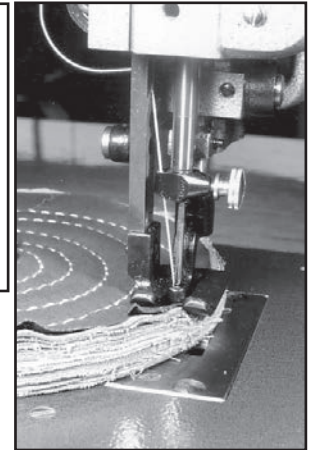

Buffing wheels

Specifications

Variety	SLH-2B-FH-1H	
Number of needle	Single needle	
Max. sewing speed	600 s.p.m.	
Max. stitch length	19/32" (15 mm)	
Clearance under presser foot	by hand	1-37/64" (40 mm)
	by pedal	1-37/64" (42 mm)
Needle bar stroke	2-7/8" (73 mm)	
Needle(standard)	ORGAN 1001H (#28) / Schmetz 1000 (#250)	
Thread	#0 (standard) - #00	
Hook	Large shuttle hook	
Amount of lift of alternating presser foot	3/16"-9/32" standard 15/64" (5 - 7 mm) (standard 6 mm)	
Thread take up lever	Cam type	
Lubrication	Hand type	
Bed size	25-3/4" x 10-5/32" (654 x 258 mm)	
Working space	16-1/4"x 9-3/32" (413 x 231 mm)	
Motor / Motor Belt	AC Servo motor (750w) / A type	
Net weight(Head only)	113 kg	

NOTE: (1) Speed depends on threads, materials and type of operation (2) Specifications subject to change without notice



SEIKO SEWING MACHINE CO., LTD.

2-13-6, Sakaecho, Funabashi-shi
Chiba Prefecture, 273-0018, Japan
Phone : +81-47-420-3561 (Overseas dept.)
Fax : +81-47-420-3560
E-mail : export@seiko-sewing.co.jp

Printed in Japan 2016.04

<http://www.seiko-sewing.co.jp/>

STH-8BLD-3

Single needle, Large horizontal axis hook, Compound feed and walking foot, Reverse stitch, Lockstitch machine

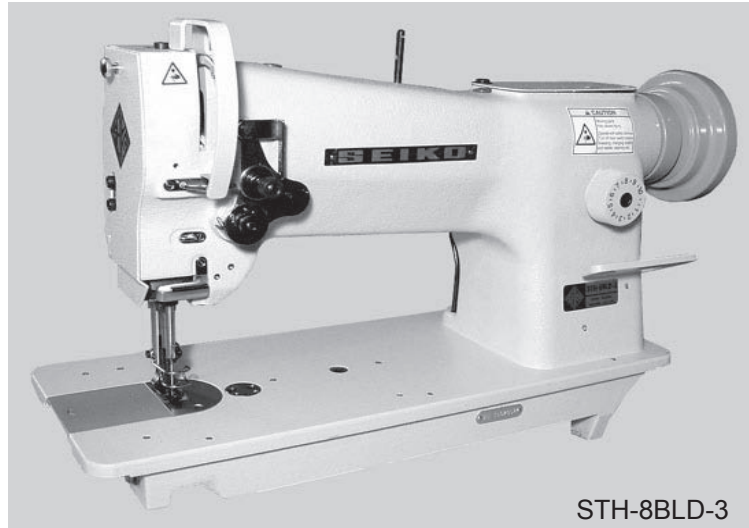

Variety

STH-8BLD-3

Applications

- For sewing medium to heavy weight materials such as fabrics, leather, vinyl, synthetics and laminated and coated products.
- Suitable for sewing such products as automobile upholstery, covers, sails, tents, camping trailer covers, awnings, bags, luggage, handbags, etc.

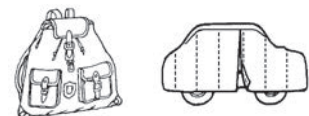

Features

- Perfect prevention of presser foot's play (pic ①)
A guide was installed to protect play at presser bar bracket. Effective to the works where side force is generated such as piping edge sewing.
- Improved the efficiency of sewing work (pic ②)
For easy sewing of curved materials, the position of thread retainer was moved upward. Also face plate is cut to narrow by 6mm than STH-8BLD-2 for efficient sewing work.
- Beautiful forward & reverse stitch (pic ③)
More beautiful stitch is realized by the same stitch length adjustment of forward & reverse feed.
- Special hook(2 times) & bobbin case opener ideal for heavy weight materials (pic ④)
In case the thread jams in the hook, SEIKO SPECIAL HOOK & SAFETY CLUTCH SYSTEM protect the hook from being damaged. Also perfect stitch is realized by BOBBIN CASE OPENER.

* Easy picking out bobbin case at any needle position if it is above needle plate.

* The hook is lubricated by its own oil reservoir.

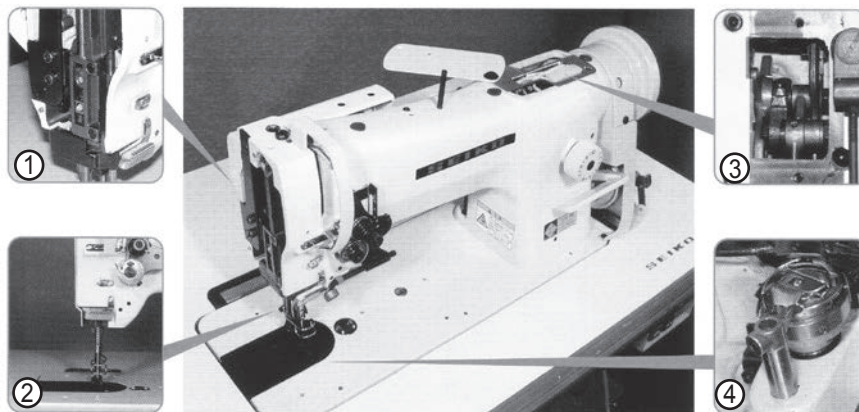

Specifications

Variety	STH-8BLD-3	
Number of needle	Single needle	
Max. sewing speed	2,000 s.p.m. / 2,400 s.p.m.: 8mm or less	
Max. stitch length	25/64" (10 mm)	
Clearance under presser foot	by knee	33/64" (13 mm)
	by hand	21/64" (8.5 mm)
Needle bar stroke	1-5/16" (33.2 mm)	
Needle(standard)	DPx17 (standard #22), 135x17 (standard #140)	
Thread	#8 (standard)	
Hook	Large horizontal axis hook (2.0 times)	
Amount of lift of walking foot	7/64"-7/32" (standard 1/8")	
	2.7 - 5.5 mm (standard 3.2 mm)	
Thread take up lever	Slide type	
Lubrication	Semi-automatic lubrication type	
Bed size	18-25/32"x 7" (477 x 177 mm)	
Working space	10-5/32"x 4-21/64" (258 x 110 mm)	
Motor	Clutch motor	
Net weight(Head only)	29 Kg	

NOTE: (1) Speed depends on threads, materials and type of operation

(2) Specifications subject to change without notice



SEIKO SEWING MACHINE CO., LTD.

2-13-6, Sakaecho, Funabashi-shi
Chiba Prefecture, 273-0018, Japan

Phone : +81-47-420-3561 (Overseas dept.)

Fax : +81-47-420-3560

E-mail : export@seiko-sewing.co.jp

Printed in Japan 2016.04

<http://www.seiko-sewing.co.jp/>

TH series

Single needle, Extra heavy duty, Large oscillating shuttle hook, Compound feed and walking foot, Reverse stitch, Long arm, Flat bed, Lockstitch machines

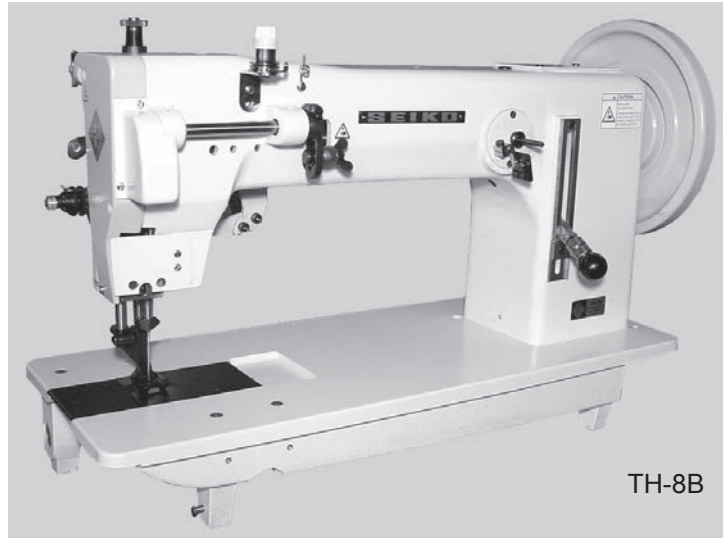

Variety

TH-8B

Applications

- For sewing heavy weight materials such as canvas, vinyl, leather, synthetics and various coated, laminated and rubberized fabrics.
- Suitable for sewing tents, sails, harnesses, safety belts, parachutes, balloons, industrial bags, book bindings, suitcases and other extra heavy weight materials.



Features

- Large oscillating shuttle hook with extra large capacity bobbin.
- Extra long arm. [working space 15-3/4"(400 mm)]
- Reverse stitching by stitch adjusting lever.
- Built-in bobbin winder.
- Extra high presser lift for sewing extra heavy materials.
- Cylinder bed version available. (CH series)

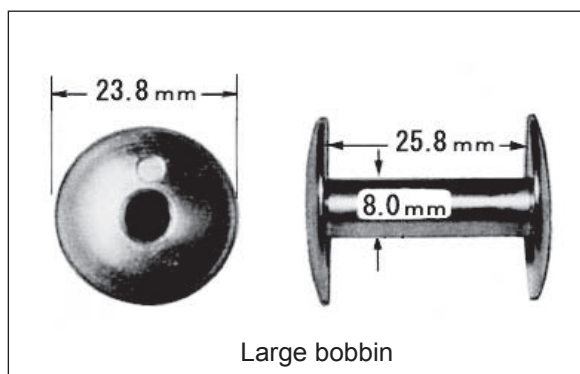

Specifications

Variety	TH-8B	
Number of needle	Single needle	
Max. sewing speed	800 s.p.m.	
Max. stitch length	15/32" (12 mm)	
Clearance under presser foot	by knee	63/64" (25 mm)
	by hand	25/64" (10 mm)
Needle bar stroke	2-13/64" (56 mm)	
Needle(standard)	DYx3 (#25) , 794 (#200)	
Thread	#5 (standard)	
Hook	Large oscillating shuttle hook	
Amount of lift of walking foot	1/8"-15/64" standard 5/32" (3 - 6 mm) (standard 4 mm)	
Thread take up lever	Cam type	
Lubrication	Hand type	
Bed size	25-63/64"x 9-61/64" (660 x 253 mm)	
Working space	15-3/4"x 7" (400 x 180 mm)	
Motor	Clutch motor	
Net weight(Head only)	75 Kg	

NOTE: (1) Speed depends on threads, materials and type of operation
(2) Specifications subject to change without notice



SEIKO SEWING MACHINE CO., LTD.

2-13-6, Sakaecho, Funabashi-shi
Chiba Prefecture, 273-0018, Japan
Phone : +81-47-420-3561 (Overseas dept.)
Fax : +81-47-420-3560
E-mail : export@seiko-sewing.co.jp

Printed in Japan 2016.04

<http://www.seiko-sewing.co.jp/>

THM-26B-1-FL

Two needle, Extra heavy duty, Multi different ornamental stitching, Drop feed, Roller foot, Reverse stitch, Large shuttle hook, Semi-Long arm, Flat bed, Lockstitch machine



THM-26B-1-FL

Variety

THM-26B-1-FL

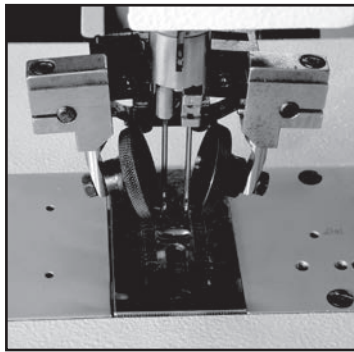

Needle & Roller Presser

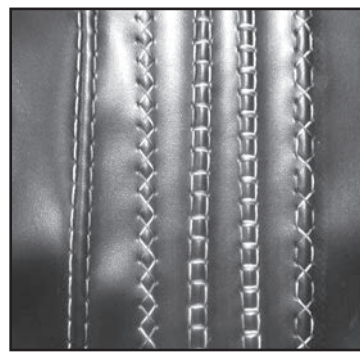

5 Stitches

Applications

- For sewing heavy weight materials such as canvas, vinyl, leather, synthetics, synthetics and rubberized fabrics, various coated, laminated fabrics, etc.
- Suitable for sewing sofas, tents, shoe uppers, suitcases, bags, jeans, sunshade, etc.

Features

- Produce five(5) different ornamental stitches.
- Suitable for heavy materials.
- Automatic presser foot lift.
- Semi-Long arm (working space 320 mm).
- Cord insert available.
- Reverse stitching by stitch adjusting lever.
- Easy to change the cam.
- Available to adjust the height of roller presser foot at 4.0mm MAX.

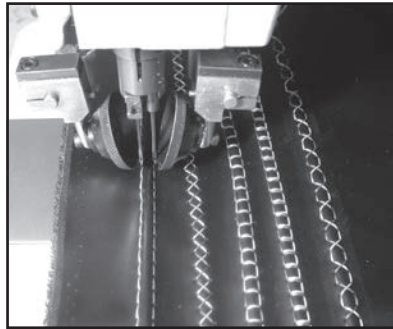

SEWING CONDITION

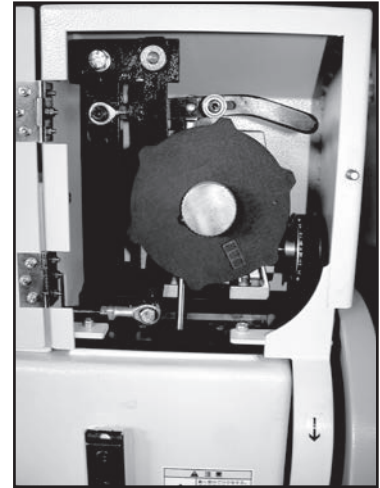

CAM SECTION

Specifications

Variety	THM-26B-1-FL
Number of needle	Two needle
Max. sewing speed	550 s.p.m.
Max. stitch length	5/16" (8 mm)
Clearance under presser foot	25/64" (9 mm)
Needle bar stroke	2-13/64" (50 mm)
Needle(standard)	DDx1 (#24)
Thread	#2 - #00 (standard #2)
Needle Gauge	6.0mm (standard) , 8.0mm
Hook	Large oscillating shuttle hook
Presser foot lifting	Pneumatic
Thread take up lever	Cam type
Lubrication	Hand type
Bed size	572 x 253 mm
Working space	320 x 182 mm
Motor	AC Servo Motor
Net weight(Head only)	73 Kg

NOTE: (1) Speed depends on threads, materials and type of operation (2) Specifications subject to change without notice



SEIKO SEWING MACHINE CO., LTD.

2-13-6, Sakaecho, Funabashi-shi
Chiba Prefecture, 273-0018, Japan

Phone : +81-47-420-3561 (Overseas dept.)

Fax : +81-47-420-3560

E-mail : export@seiko-sewing.co.jp

Printed in Japan 2016.04

<http://www.seiko-sewing.co.jp/>

BBWP series

High speed, Post bed, Compound feed and walking foot,
Large vertical axis hook, Reverse stitch, Lockstitch machines

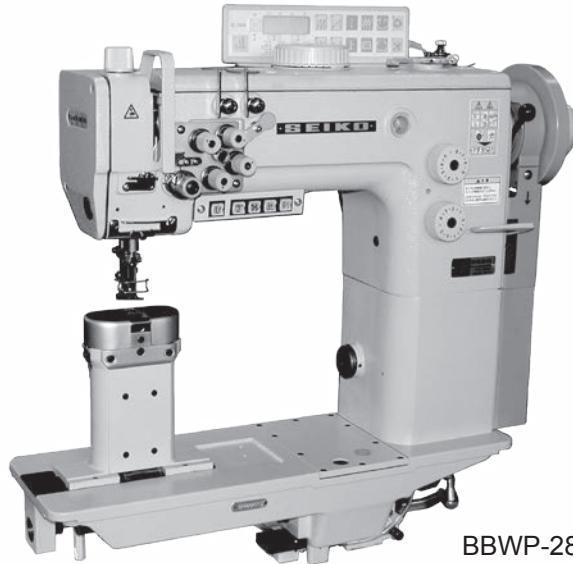

BBWP-28BL-BTFL-CD-DS

Variety



BBWP-8BL

Single needle.



BBWP-8BL-BTFL

Single needle, automatic back tack, automatic presser foot lift.



BBWP-8BL-BTFL-CD-DS

Single needle, automatic back tack, automatic presser foot lift, climbing device, dual stitching device.



BBWP-28BL

Two needle.



BBWP-28BL-BTFL

Two needle, automatic back tack, automatic presser foot lift.



BBWP-28BL-BTFL-CD-DS

Two needle, automatic back tack, automatic presser foot lift, climbing device, dual stitching device.

Applications

- For sewing medium to heavy weight materials such as leather, vinyl, synthetics and laminated and coated materials
- Suitable for sewing such as automobile upholstery tarpaulins, covers, awnings, tents, umbrellas, handbags, luggage, travelware accessories, sports and camping equipment and wearing apparel outdoor clothing.



Features

- Longer stitch length quiet sewing operation
 - * Max. 9mm for both forward and reverse feed stitching.
 - * Compound feed and walking foot for positive stitching formation.
- BBWP series are equipped with a large vertical axis hook(2.0 times)
 - * Large capacity hook minimizes the time to replace the bobbin thread in stitching of thick thread.
 - * This hook promote highly efficient operation by reducing the frequency of bobbin thread replacement.
- Safety device
 - * Safety device prevents damage to hook and thread handling parts caused by thread jamming.
- One touch switchover for two different stitch lengths (DS device)
 - * Variety sewing materials such as steps, curves, uneven thickness can be performed by one touch switchover setting two different stitch lengths. The efficient work and beautiful finishes will be obtained.

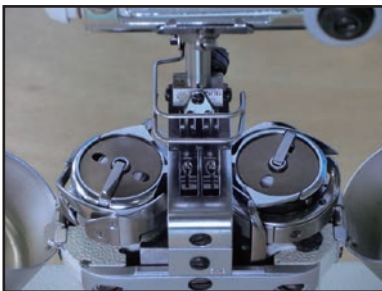

2.0 times large capacity hook

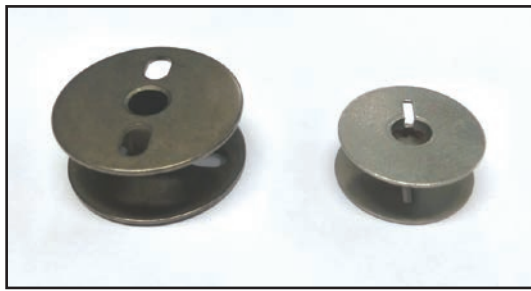

Comparison of the bobbin size

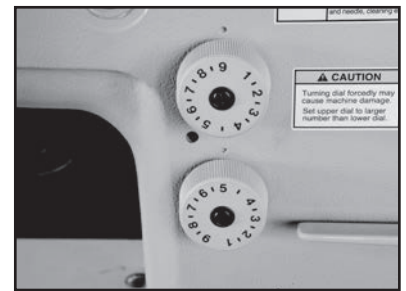

One touch switchover for two different stitch lengths (DS device)

- Built-in bobbin winder
 - * Built-in bobbin winder makes it possible to wind the bobbin thread during sewing operation.
- Wide working space
 - * 300 mm working space, from the needle to the sewing machine arm, makes sewing works easy to handle heavy weight and even large materials.
- Large clearance under presser foot
 - * The clearance under the presser foot (16mm), makes it easy to put heavy weight materials in and out.

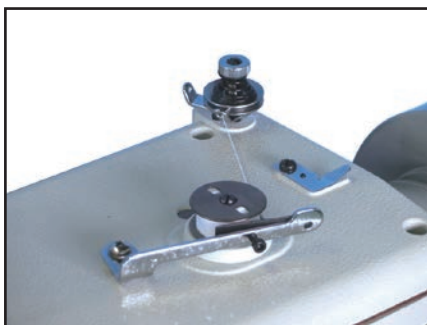

Built-in bobbin winder

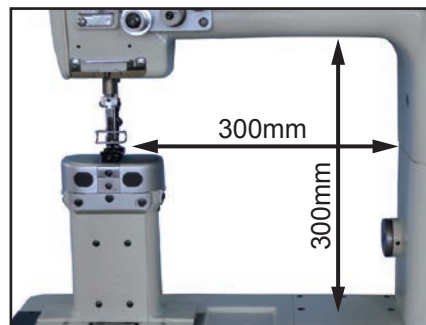

Wide working space



The clearance under the presser foot (16mm)

- Simple setting for alternating presser foot movement
 - * Alternating presser foot movement between inner foot and outer foot can be changed simply by the easy-to-handle dial located at the top of the sewing machine.
 - * Once the alternating movements have been set, the sewing speed is automatically controlled to the optimum speed so that stable sewing is maintained.
- Smooth stitching on step section (CD device)
 - * The presser foot movement can be changed to maximum momentum (7mm) by button. Uneven thickness of materials can be smoothly performed changing the movement right before the uneven point.

BBWP series

- 5 operational switches improve working efficiency

- * 5 switch buttons are panelled on the convenient positions improve the efficient works.



Simple setting for alternating presser foot movement

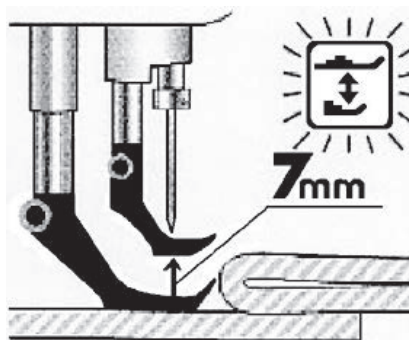

Smooth stitching on step section (CD device)

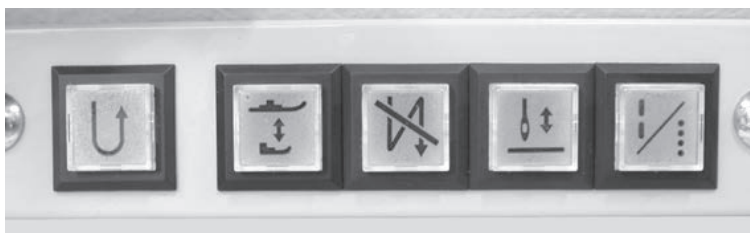

5 operational switches

- * Quick reverse switch
- * Walking foot movement change switch
- * Auto backtack select switch
- * Half stitch switch
- * Stitch length change switch

- Center guide (optional parts)

- * Lifting presser foot with a central guide (optional parts)

- Guide (optional parts)

- * The edge roller guide (Part no.60546C) which is being used by BBW series machine can be used in its as is status.



On duty



Off duty

BBWP series

Specifications (BBWP-□)

Variety	8BL	8BL-BTFL	8BL-BTFL-CD-DS	28BL	28BL-BTFL	28BL-BTFL-CD-DS
Number of needle	Single needle			Two needle		
Max. sewing speed	2,500s.p.m. (Refer to list below)					
Max. stitch length	9 mm					
Clearance under presser foot	by hand	9 mm				
	by knee	16 mm	-	16 mm	-	
	by automatic foot lifter	-	16 mm	-	16 mm	
Needle bar stroke	34 mm					
Needle (Standard)	135 × 17 #110 - #200 (#180), DP × 17 #18 - #25 (#24)					
Thread	#20 - #1 (Standard #5)					
Hook	Large vertical axis hook (2.0 times)					
Post height	178 mm					
Thread take up lever	Link type					
Amount of walking foot movement	1-6.5mm	1-7 mm		1-6.5mm	1-7 mm	
Walking foot movement change switch	Dial type					
Bobbin winder	Built-in type located at the top of the sewing machine					
Auto presser foot lifting device	-	Pneumatic		-	Pneumatic	
Walking foot movement change device	-	Pneumatic		-	Pneumatic	
Safety device	Standard					
Lubrication	Semi-automatic lubrication type					
Bed size / Working space	567 × 177 mm / 300 × 300 mm					
Net weight (Head only)	61Kg	63Kg	64Kg	61Kg	63Kg	64Kg
Motor	Clutch motor	AC Servo motor		Clutch motor	AC Servo motor	

NOTE : (1)Speed depends on threads, materials and type of operation. (2)Specifications subject to change without notice

Sewing speed range

Amount of walking foot movement	Stitch length	
	6 mm and less	6 mm ~ 9 mm
1 mm ~ 2 mm	2500 s.p.m	2000 s.p.m.
3 mm	2400 s.p.m.	
4 mm	2300 s.p.m.	
5 mm ~ 7 mm	2000 s.p.m.	

BBWP-□

	8BL-BTFL	8BL-BTFL-CD-DS
Quick reverse feed (BT)	○	○
Auto presser foot lifting (FL)	○	○
Walking foot movement changeover (CD)	-	○
Stitch length change (DS)	-	○

Needle gauge list

Variety	Needle gauge size
BBWP-28BL	standard : 1/4"(6.4 mm), 5/16"(7.9 mm), 3/8"(9.5 mm) special : 1/8"(3.2 mm), 3/16"(4.8 mm)



SEIKO SEWING MACHINE CO., LTD.

2-13-6, Sakaecho, Funabashi-shi
Chiba Prefecture, 273-0018, Japan

Phone : +81-47-420-3561 (Overseas dept.)

Fax : +81-47-420-3560

E-mail : export@seiko-sewing.co.jp

Printed in Japan 2016.04

<http://www.seiko-sewing.co.jp/>

LHPWN series

Single needle, High speed, Extra high post bed, Compound feed and walking foot, Reverse stitch, left post, Lockstitch machines



LHPWN-8B-3-SF-LP

Variety



LHPWN-8B-3-SF-LP

Slim post, standard vertical axis hook



LHPWN-8B-3-TA-SF-LP

Slim post, standard vertical axis hook, for thick thread



LHPWN-8BL-3-LP

Large vertical axis hook

Applications

- For sewing medium to heavy weight materials such as leather, vinyl, synthetics and laminated and coated materials.
- Suitable for sewing such products as bags, boots, travel cases and automobile upholstery.

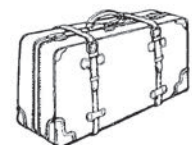

LHPWN series

Features (LHPWN-□)

- Improved exposure of arm-feeding mechanism components which provides safety environment. (mechanical part of alternating presser foot, foot lifter mechanism(knee lifter) and presser foot spring)
- Extra high post 17" bed and wide working space makes it easy for sewing of large materials.
- The reduced distance between the needle and the edge of throat plate (2.0mm) for sewing goods with narrow margin beautifully.(8B-3-SF-LP, 8B-3-TA-SF-LP only as an option)
- Available to sew the smaller materials by new designed throat plate and hook cover. (8B-3-SF-LP, 8B-3-TA-SF-LP only as an option)
- Easy to adjust the stitch length by adjusting Dial.
- Safety clutch prevents the hook from being damaged.
- Right post type is available.



LHPWN-8B-3-SF-LP



LHPWN-8BL-3-LP

Specifications (LHPWN-□)

Variety	8B-3-SF-LP	8B-3-TA-SF-LP	8BL-3-LP
Number of needle	Single needle		
Max. sewing speed	1,600 s.p.m.	1,200 s.p.m.	2,200 s.p.m.
Max. stitch length	13/64" (5 mm)	9/32" (7 mm)	7/32" (5.5 mm)
Clearance under presser foot	by pedal	5/8" (16 mm)	
	by hand	25/64" (10 mm)	
Needle bar stroke	1-25/64" (35.4 mm)		
Needle(standard)	DPx17(#22), 135x17(#140)	DPx17(#25), 135x17(#200)	DPx17(#22), 135x17(#140)
Thread	#8 (standard)	lower #8, upper #0	#8 (standard)
Hook	Vertical axis hook		Large vertical axis hook (2.0times)
Amount of lift of walking foot	7/64"-7/32" (2.7 - 5.5 mm)		
Thread take up lever	Slide type		
Lubrication	Semi-automatic lubrication type		
Bed size	20-25/64"x 7" (518 x 177 mm)		
Working space	10-5/32"x 21-25/32" (258 x 553 mm)		
Post height	17-33/64" (445 mm)		17-7/16" (443 mm)
Motor	Clutch motor		
Net weight(Head only)	64 Kg		67.5 Kg

NOTE: (1) Speed depends on threads, materials and type of operation
 (2) Specifications subject to change without notice



SEIKO SEWING MACHINE CO., LTD.

2-13-6, Sakaecho, Funabashi-shi
 Chiba Prefecture, 273-0018, Japan
 Phone : +81-47-420-3561 (Overseas dept.)
 Fax : +81-47-420-3560
 E-mail : export@seiko-sewing.co.jp



Printed in Japan 2016.04

<http://www.seiko-sewing.co.jp/>

LPW-28BLK (angular stitch)

Two needle, High speed, Post bed, Large vertical axis hook, Compound feed and walking foot, Reverse stitch, Disengageable needle bars, Lockstitch machine



LPW-28BLK

Variety

LPW-28BLK

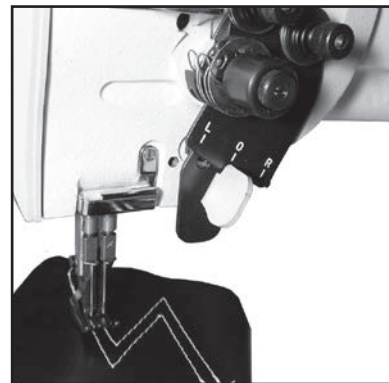

Angular stitching and/or straight stitching can be made by simplified operation

Applications

- For sewing medium to heavy weight fabrics, leather, vinyl, synthetics and laminated and coated materials.
- Suitable for sewing operations which require decorative or functional angular stitching such as collars, pockets, shoe uppers, automobile upholstery, etc.



LPW-28BLK (angular stitch)

Features

- Post bed and wide working space makes it easy for sewing of large materials.
- Easy operation of disengageable right and left needle bars by use of finger touch lever.
- Compound feed and alternating pressers mechanism assures even feeding of materials.
- Semi-automatic lubrication system.
- Large vertical axis hook.
- Safety clutch prevents the hook from being damaged.

Specifications

Variety	LPW-28BLK	
Number of needle	Two needle	
Max. sewing speed	2,200 s.p.m.	
Max. stitch length	7/32" (5.5 mm)	
Clearance under presser foot	by knee	35/64" (14 mm)
	by hand	21/64" (8.5 mm)
Needle bar stroke	1-9/32" (32.6 mm)	
Needle(standard)	DPx17 (#24) , 135x17 (#180)	
Thread	#5 (standard)	
Hook	Large vertical axis hook (2.0times)	
Amount of lift of walking foot	3/32"-3/16" standard 1/8" (2.5 - 5 mm) (standard 3.2 mm)	
Thread take up lever	Slide type	
Lubrication	Semi-automatic lubrication type	
Bed size	20-25/64" x 7" (518 x 177 mm)	
Post height	7" (178 mm)	
Working space	10-5/32"x11-11/32" (258 x 288 mm)	
Motor	Clutch motor	
Net weight(Head only)	44 Kg	

NOTE: (1) Speed depends on threads, materials and type of operation
(2) Specifications subject to change without notice

Needle gauge list

Variety	Needle gauge size
LPW-28BLK	standard : 1/4"(6.4 mm), 5/16"(7.9 mm), 3/8"(9.5 mm) special : 1/8"(3.2 mm), 3/16"(4.8 mm)



SEIKO SEWING MACHINE CO., LTD.

2-13-6, Sakaecho, Funabashi-shi
Chiba Prefecture, 273-0018, Japan

Phone : +81-47-420-3561 (Overseas dept.)

Fax : +81-47-420-3560

E-mail : export@seiko-sewing.co.jp

Printed in Japan 2016.04

<http://www.seiko-sewing.co.jp/>

PW series

High speed, Post bed, Vertical axis hook, Drop feed, Reverse stitch, Lockstitch machines

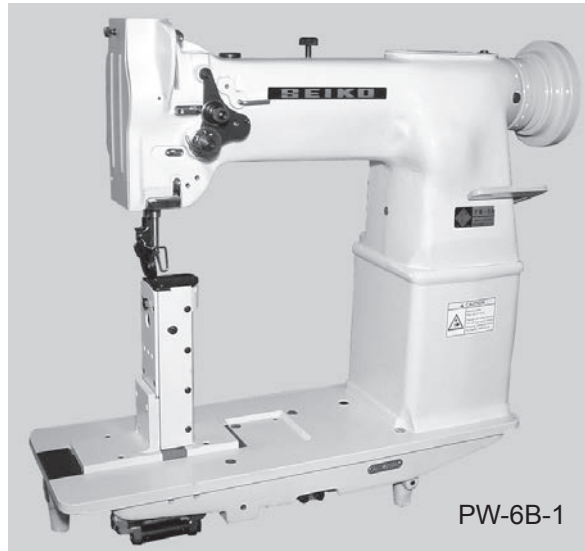

PW-6B-1

Variety

 **PW-6B-1**
Single needle

 **PW-26B-1**
Two needle



PW-26B-1

Applications

- For sewing medium to heavy weight fabrics, leather, vinyl, synthetics and laminated and coated materials.
- Suitable for sewing such as raincoats, underwear, overalls, foundation garments, corsets and shoes.



Features (PW-□)

- Post bed and wide working space makes it easy for sewing of large materials.
- Roller presser foot allows for turning of sharp corners and tight curves.

* Roller presser foot is to be fitted with 3/64"-3/32" gauge size machine as standard (26B-1)

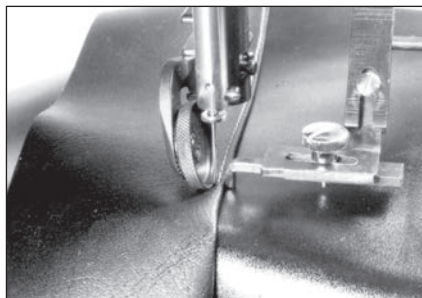

PW-6B-1

Specifications (PW-□)

Variety	6B-1	26B-1
Number of needle	Single needle	Two needle
Max. sewing speed	2,800 s.p.m.	2,500 s.p.m.
Max. stitch length	11/64" (4.5 mm)	
Clearance under presser foot	by knee	5/16" (8 mm)
	by hand	15/64" (6 mm)
Needle bar stroke	1-5/16" (33.2 mm)	
Needle(standard)	DPxF22 (#14) , 134KKS (#90)	
Thread	#30 (standard)	
Hook	Vertical axis hook	
Thread take up lever	Slide type	
Lubrication	Hand type	
Bed size	20-25/64" x 7" (518 x 177 mm)	
Post height	7" (178 mm)	
Working space	10-5/32" x 11-11/32" (258 x 288 mm)	
Motor	Clutch motor	
Net weight(Head only)	39Kg	40Kg

NOTE: (1) Speed depends on threads, materials and type of operation
 (2) Specifications subject to change without notice

Needle gauge list

Variety	Needle gauge size
PW-26B-1	standard : 1/16"(1.6 mm), 3/32"(2.4 mm) special : 3/64"(1.2 mm), 5/64"(2.8 mm)



SEIKO SEWING MACHINE CO., LTD.

2-13-6, Sakaecho, Funabashi-shi
 Chiba Prefecture, 273-0018, Japan

Phone : +81-47-420-3561 (Overseas dept.)

Fax : +81-47-420-3560

E-mail : export@seiko-sewing.co.jp

Printed in Japan 2016.04

<http://www.seiko-sewing.co.jp/>

CH series

Single needle, Extra heavy duty, Large oscillating shuttle hook, Reverse stitch, Long arm, Cylinder bed, Lockstitch machines

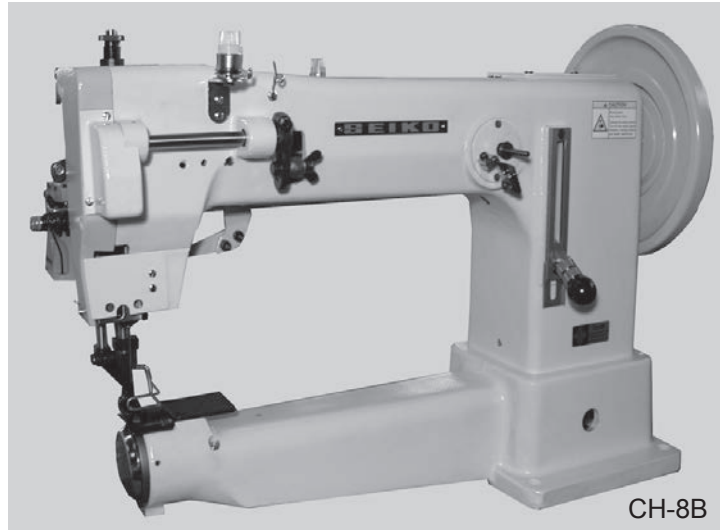

CH-8B

Variety



CH-7B

Compound feed



CH-8B

Compound feed and walking foot

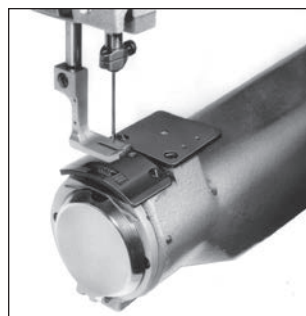

CH-7B



CH-8B

Applications

- For sewing heavy weight materials such as canvas, vinyl, leather, synthetics and various coated, laminated and rubberized fabrics.
- Suitable for sewing tubular and curved work, etc.



Features

- Large oscillating shuttle hook with extra large capacity bobbin.
- Extra long arm. [working space 15-3/4"(400 mm)]
- Extra high presser lift for sewing extra heavy materials.
- Reverse stitch by stitch adjusting lever.
- Built-in bobbin winder.
- Automatic back tack(BT) and automatic presser foot lift(FL) are available.

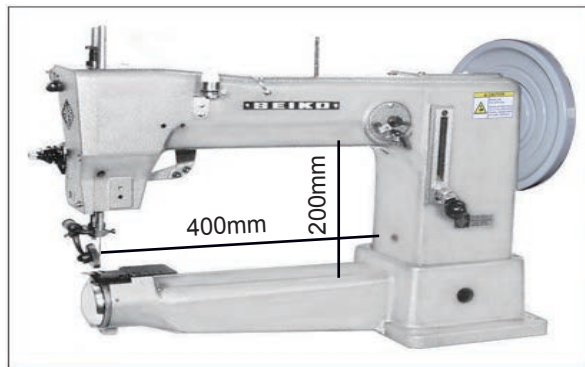
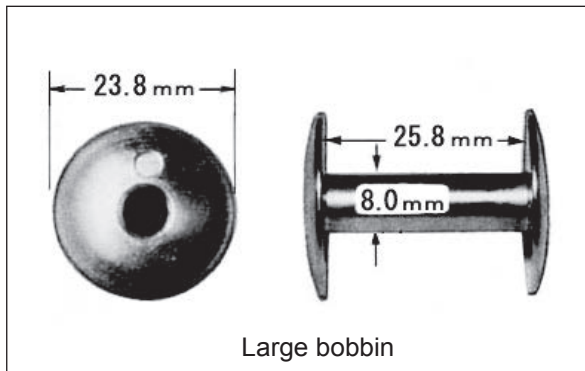

The practical use of wide working space(200 × 400), high presser lift amount (20mm by knee lifter) and large hook make it possible wide application for heavy weight materials.

Specifications (CH-□)

Variety		7B	8B
Number of needle		Single needle	
Max. sewing speed		800 s.p.m.	
Max. stitch length		25/64" (10 mm)	
Clearance under presser foot	by knee	25/32" (20 mm)	63/64" (25 mm)
	by hand	25/64"(10 mm)	25/64" (10 mm)
Needle bar stroke		2" (51 mm)	2-13/64"(56 mm)
Needle(standard)		DDx1(#24), 328(#180)	DYx3 (#24), 794(#180)
Hook		Large oscillating shuttle hook	
Amount of lift of walking foot		-	1/8"-15/64" standard 5/32" (3 - 6 mm) (standard 4 mm)
Thread take up lever		Cam type	
Lubrication		Hand type	
Bed size		23-5/8"x 3-15/64" (600 x 82 mm)	
Cylinder size		3-15/64" (82 mm) dia.	
Working space		15-3/4"x 7-7/8" (400 x 200 mm)	
Motor		Clutch motor	

NOTE: (1) Speed depends on threads, materials and type of operation
(2) Specifications subject to change without notice



SEIKO SEWING MACHINE CO., LTD.

2-13-6, Sakaecho, Funabashi-shi
Chiba Prefecture, 273-0018, Japan
Phone : +81-47-420-3561 (Overseas dept.)
Fax : +81-47-420-3560
E-mail : export@seiko-sewing.co.jp

Printed in Japan 2016.04

<http://www.seiko-sewing.co.jp/>

CW series

Single needle, High speed, Cylinder bed, Vertical axis hook,
Compound feed and walking foot, Reverse stitch, Lockstitch machines



Variety

CW-8B-2

Applications

- Designed for stitching tubular and curved work.
- Suitable for sewing such products as caps, cushions, boots, shoes, bags, luggage, handbags, travelware accessories, etc.

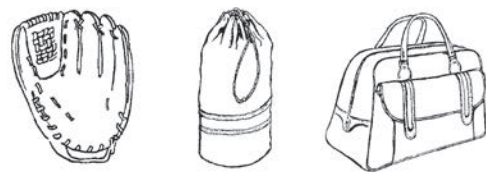

Features

- Vertical axis hook.
- Safety clutch prevents the hook from being damaged.
- Reverse stitching by stitch adjusting lever.
- Compound feed and walking foot mechanism assures even feeding of materials.
- Semi-automatic lubrication system and large hook machines are available. (LCW series)

Specifications

Variety	CW-8B-2	
Number of needle	Single needle	
Max. sewing speed	2,500 s.p.m.	
Max.stitch length	13/64" (5 mm)	
Clearance under presser foot	by pedal	35/64" (14 mm)
	by hand	21/64" (8.5 mm)
Needle bar stroke	1-5/16" (33.2mm)	
Needle(standard)	DPx17 (#22) , 135x17 (#140)	
Thread	#8 (standard)	
Hook	Vertical axis hook	
Amount of lift of walking foot	7/64"-7/32" standard 1/8" (2.7 - 5.5 mm) (standard 3.2 mm)	
Thread take up lever	Slide type	
Lubrication	Hand type	
Cylinder size	2-9/16"(65 mm) dia.	
Working space	10-5/32"x 4-21/64" (258 x 110 mm)	
Motor	Clutch motor	
Net weight(Head only)	32Kg	

NOTE: (1) Speed depends on threads, materials and type of operation
 (2) Specifications subject to change without notice



SEIKO SEWING MACHINE CO., LTD.

2-13-6, Sakaecho, Funabashi-shi
 Chiba Prefecture, 273-0018, Japan
 Phone : +81-47-420-3561 (Overseas dept.)
 Fax : +81-47-420-3560
 E-mail : export@seiko-sewing.co.jp



Printed in Japan 2016.04

<http://www.seiko-sewing.co.jp/>

LCW single needle series

High speed, Cylinder bed, Large Vertical axis hook, Compound feed
Compound feed and walking foot, Reverse stitch, Lockstitch machines



LCW-8BL

Variety

LCW-8BL

LCW-8BL-TA

For thick thread

LCW-8BL-1

Small sized cylinder edge

LCW-8BL-1-TA

Small sized cylinder edge, for thick thread

LCW-8BLV

Synchronized binding

LCW-8BLV-1

Synchronized binding, small sized cylinder edge

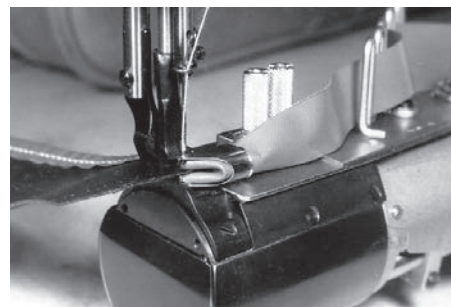

Synchronized binding machine

Applications

- For sewing medium to heavy weight fabrics, leather, synthetics, canvas and various coated and laminated materials.
- Suitable for sewing tubular and curved work such as shoes, boots, bags and handbags.



LCW single needle series

Features (LCW-□)

- Semi-automatic lubrication system.
- Large vertical axis hook.
- Safety clutch prevents the hook from being damaged.
- Reverse stitching by stitch adjusting lever.
- Special designed cylinder edge for the special stitching on uneven materials. (8BL-1, 8BL-1-TA, 8BLV-1)
- Synchronized binder available (8BLV, 8BLV-1)

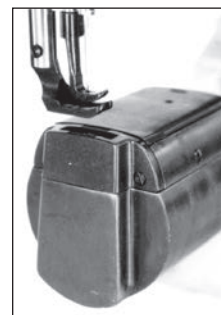

LCW-8BL-1

Specifications (LCW-□)

Variety	8BL	8BL-1	8BLV	8BLV-1	8BL-TA	8BL-1-TA
Number of needle	Single needle					
Max. sewing speed	2,000 s.p.m.				1,800 s.p.m.	
Max. stitch length	1/4" (6.2 mm)					
Clearance under presser foot	by pedal		35/64" (14 mm)			
	by hand		21/64" (8.5 mm)			
Needle bar stroke	1-5/16" (33.2 mm)					
Needle(standard)	DPx17 (#22) , 135x17 (#140)				DPx17 (#25) , 135x17 (#200)	
Thread	#8 (standard)				#0 (Upper & Lower thread)	
Hook	Large vertical axis hook (2.0times)					
Amount of lift of walking foot	7/64"-7/32" (2.7 - 5.5 mm)		standard 1/8" (standard 3.2 mm)			
Thread take up lever	Slide type					
Lubrication	Semi-automatic lubrication type					
Cylinder size	3-1/32"(77 mm) dia.					
Working space	10-5/32"x 4-21/64" (258 x 110 mm)					
Motor	Clutch motor					
Net weight(Head only)	33Kg				34Kg	

NOTE: (1) Speed depends on threads, materials and type of operation
 (2) Specifications subject to change without notice



SEIKO SEWING MACHINE CO., LTD.

2-13-6, Sakaecho, Funabashi-shi
 Chiba Prefecture, 273-0018, Japan

Phone : +81-47-420-3561 (Overseas dept.)

Fax : +81-47-420-3560

E-mail : export@seiko-sewing.co.jp

Printed in Japan 2016.04

<http://www.seiko-sewing.co.jp/>

LCW two needle series

High speed, Cylinder bed, Large vertical axis hook, Compound feed and walking foot, Reverse stitch, Lockstitch machines



LCW-28BL

Variety

LCW-28BL

Applications

- For sewing medium to heavy weight fabrics, leather, synthetics, canvas and various coated and laminated materials.
- Suitable for sewing tubular and curved work such as shoes boots, bags and handbags.



LCW two needle series

Features

- Semi-automatic lubrication system.
- Large vertical axis hook.
- Safety clutch prevents the hook from being damaged.
- Reverse stitching by stitch adjusting lever.
- 20 & 30 inches long arm models are available.

Specifications

Variety	LCW-28BL	
Number of needle	Two needle	
Max. sewing speed	1,800 s.p.m.	
Max. stitch length	1/4" (6.2 mm)	
Clearance under presser foot	by pedal	35/64" (14 mm)
	by hand	21/64" (8.5 mm)
Needle bar stroke	1-5/16" (33.2 mm)	
Needle(standard)	DPx17 (#22) , 135x17 (#140)	
Thread	#8 (standard)	
Hook	Large vertical axis hook (2.0times)	
Amount of lift of walking foot	7/64"-7/32" (2.7 - 5.5 mm) standard 1/8" (standard 3.2 mm)	
Thread take up lever	Slide type	
Lubrication	Semi-automatic lubrication type	
Cylinder size	3-7/64"(79 mm) dia.	
Working space	10-5/32" x 4-21/64" (258 x 110 mm)	
Motor	Clutch motor	
Net weight(Head only)	34Kg	

NOTE: (1) Speed depends on threads, materials and type of operation
(2) Specifications subject to change without notice

Needle gauge list

Variety	Needle gauge size
LCW-28BL	Standard : 1/4"(6.4 mm), 5/16"(7.9mm), 3/8"(9.5mm), 1/2"(12.7mm)



SEIKO SEWING MACHINE CO., LTD.

2-13-6, Sakaecho, Funabashi-shi
Chiba Prefecture, 273-0018, Japan

Phone : +81-47-420-3561 (Overseas dept.)

Fax : +81-47-420-3560

E-mail : export@seiko-sewing.co.jp

Printed in Japan 2016.04

<http://www.seiko-sewing.co.jp/>

LSC series

Single needle, High speed, Narrow Cylinder bed, Horizontal axis hook, Compound feed and walking foot, Reverse stitch, Lockstitch machines

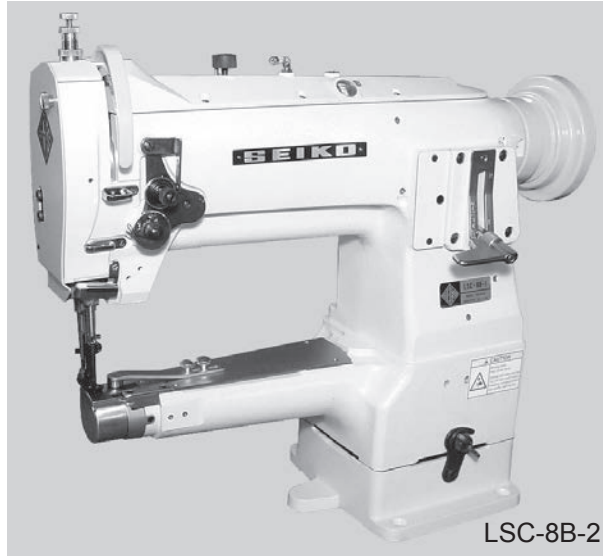

LSC-8B-2

Variety



LSC-8B-2

Standard hook



LSC-8BV-2

Standard hook, synchronized binder



LSC-8BLV-1

Large hook, synchronized binder



LSC-8BLH-1

Large hook, horizontal feed



LSC-8BHC

Standard hook, thread trimmer, horizontal feed



LSC-8BLV-1

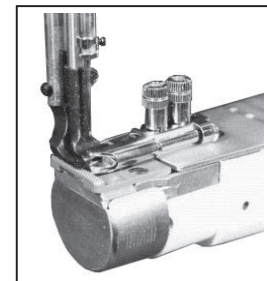

Synchronized binder

Applications

- For sewing medium to heavy weight fabrics, leather, vinyl, synthetics and laminated and coated materials.
- Suitable for tubular and curved products with narrow openings such as hats, caps, shoes, bags, handbags, etc.

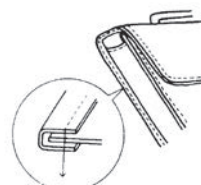
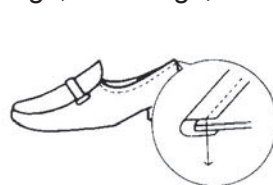

Features (LSC-□)

- Narrow cylinder bed 1-13/16"(46 mm) dia.
* Large hook machines : 1-31/32"(50 mm) dia.
- Semi-automatic lubrication system.
- Horizontal axis hook (standard or large capacity hook).
- Reverse stitching by stitch adjusting lever.
- Thread trimmer. (8BHC)
- Compound feed and walking foot mechanism assures even feeding of several piles or of slippery materials.
- Synchronzied binder. (8BLV-1, 8BV-2)
- Automatic back tack (BT) and foot lift (FL) available.

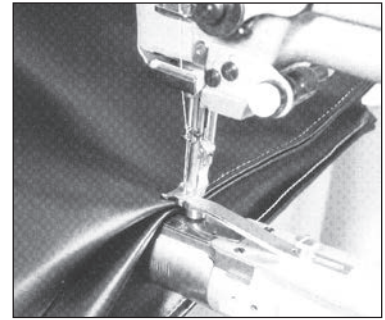

LSC-8B-2

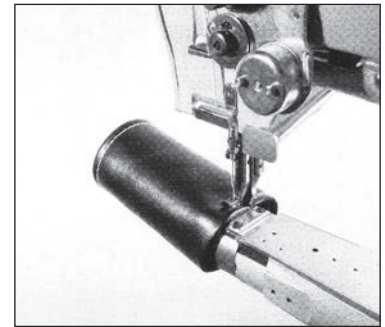

Specifications (LSC-□)

Variety	8B-2	8BV-2	8BLV-1	8BLH-1	8BHC
Number of needle	Single needle				
Max. sewing speed	2,300 s.p.m.	2,500 s.p.m.	2,200 s.p.m.		2,500 s.p.m.
Max. stitch length	15/64" (6 mm)		9/32" (7 mm)	15/64" (6 mm)	
Clearance under presser foot	by pedal				33/64" (13 mm)
	by hand				5/16" (8 mm)
Needle bar stroke	33/64" (13 mm)				
Needle(standard)	DPx17 (#18)	DPx17 (#16)	DPx17 (#16)		DPx17 (#18)
	135x17 (#110)	135x17 (#100)	135x17 (#100)		135x17 (#10)
Thread	#20(standard)	#30(standard)	#30(standard)		#20(standard)
Hook	Horizontal axis hook		Large horizontal axis hook(2.0times)		Horizontal axis hook
Amount of lift of walking foot	1/8"-15/64" standard 5/32" (3 - 6 mm) (standard 4 mm)				
Thread take up lever	Slide type				
Lubrication	Semi-automatic lubrication type				
Cylinder size	1-13/16" (46 mm) dia.		1-31/32" (50 mm) dia.		1-13/16" (46 mm) dia.
Working space	10-5/32"x 4-21/64" (258 x 110 mm)				
Motor	Clutch motor				AC servo motor
Net weight(Head only)	29 Kg				30 Kg
Feeding system	elliptical		horizontal		

NOTE: (1) Speed depends on threads, materials and type of operation
(2) Specifications subject to change without notice



SEIKO SEWING MACHINE CO., LTD.

2-13-6, Sakaecho, Funabashi-shi
Chiba Prefecture, 273-0018, Japan

Phone : +81-47-420-3561 (Overseas dept.)

Fax : +81-47-420-3560

E-mail : export@seiko-sewing.co.jp

Printed in Japan 2016.04

<http://www.seiko-sewing.co.jp/>

TE/TF series

Single needle, Cylinder bed, Oscillating shuttle hook, Drop feed, Lockstitch machines

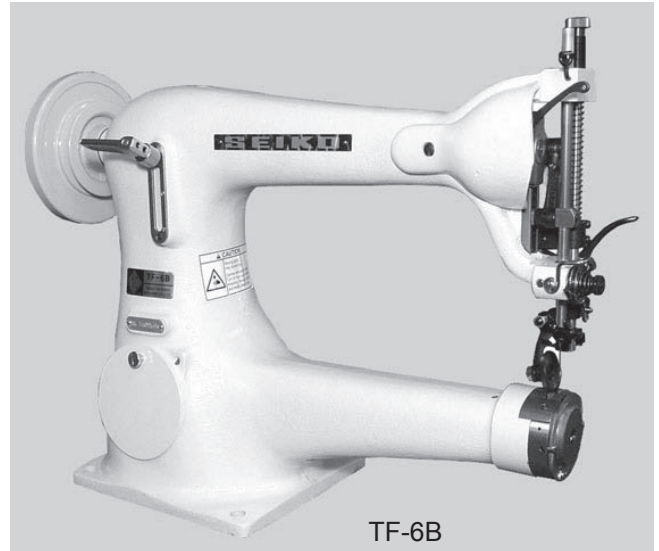

Variety

TE series

TE-6
Lower feed

TE-6B
Lower feed, reverse stitch

TF series (Left side pulley)

TF-6
Lower feed

TF-6B
Lower feed, reverse stitch

Applications

- For sewing light to medium heavy weight materials such as leather, vinyl, bags, pouches, various sports equipments and other curved work.



Features

- Standard is narrow toe presser foot and roller foot is supplied as accessories. (TE series)
- This is a convenient type machine that the left hand of the operator is usable in sewing operation, due to the feature of lefthand cylinder bed. (TF series)
- Standard foot is roller foot and narrow toe presser foot is supplied as accessories.
- Suitable for sewing of high-class products, due to the feature of the oscillating hook, which ensures perfect seam tightness.



Long beak oscillating shuttle hook

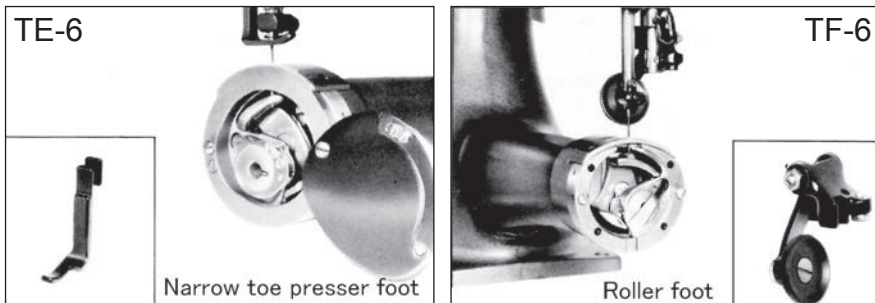

- Long beak oscillating shuttle hook
- Cam take-up
- Reverse stitching by stitch adjusting lever. (TE-6B & TF-6B)
- Cloth plate for flat work available at extra charge (Part no. 8136C)

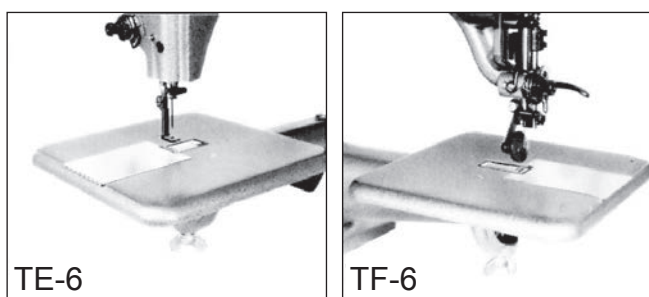

Specifications (TE-□/TF-□)

Variety	TE-6	TE-6B	TF-6	TF-6B
Number of needle	Single needle			
Max. sewing speed	1,400 s.p.m.			
Max. stitch length	15/64" (6 mm)	13/64" (4.5 mm)	13/64" (5 mm)	5/32" (3.5 mm)
Clearance under presser foot	by knee	25/64" (10 mm)		
	by hand	9/32" (7 mm)		
Needle bar stroke	1-27/64" (36 mm)			
Needle(standard)	DB× 1 (#19), 16×231 (#120)		TF× 2 (#11), 34LL (#75)	
Thread	#20 (standard)		#40 (standard)	
Hook	Long beak oscillating shuttle hook			
Presser foot	standard	Narrow toe		Roller
	Accessories	Roller		Narrow toe
Thread take up lever	Cam type			
Lubrication	Hand type			
Cylinder size	2-27/64" (61.5 mm) dia.		2-1/2" (63.5 mm) dia.	
Working space	11-1/32"x 5-5/16" (280 x 135 mm)		11-1/32"x 5-33/64" (280 x 140 mm)	
Motor	Clutch motor			
Net weight(Head only)	18 Kg		21 Kg	

NOTE: (1) Speed depends on threads, materials and type of operation
 (2) Specifications subject to change without notice



SEIKO SEWING MACHINE CO., LTD.

2-13-6, Sakaecho, Funabashi-shi
 Chiba Prefecture, 273-0018, Japan

Phone : +81-47-420-3561 (Overseas dept.)

Fax : +81-47-420-3560

E-mail : export@seiko-sewing.co.jp

Printed in Japan 2016.04

<http://www.seiko-sewing.co.jp/>

LZ2 series

Single needle, Light to medium duty, Large horizontal axis hook, Reverse stitch, Zig-zag stitch(Lockstitch) machines

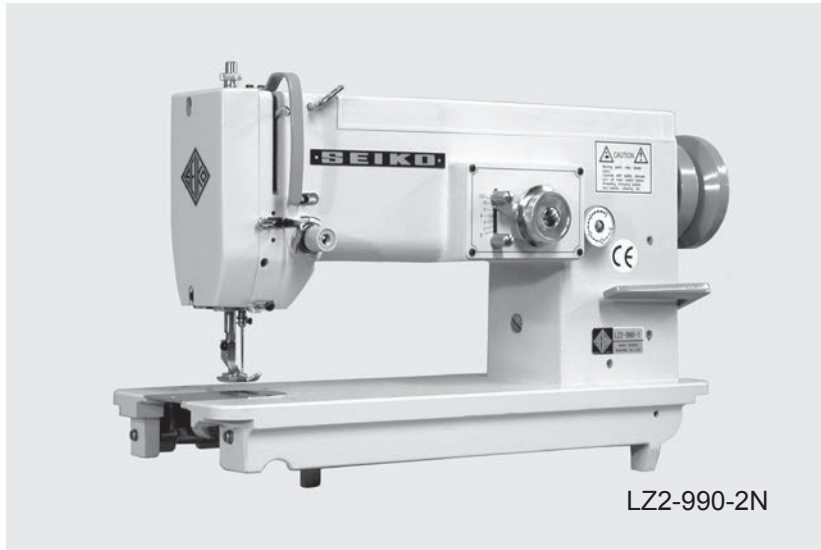

LZ2-990-2N

Variety

2-point(1-step) zig-zag

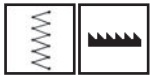

LZ2-990-2N

Drop feed



LZ2-992-2N

Upper & lower feed

4-point(3-step) zig-zag



LZ2-990-4N

Drop feed



LZ2-992-4N

Upper & lower feed

3-point(2-step) zig-zag



LZ2-990-3N

Drop feed



LZ2-992-3N

Upper & lower feed

Applications

- For sewing light to medium weight materials such as fabrics, leather, canvas, and vinyl.
- Suitable for sewing such as leather garment, shoe upper, leather glove.

Features

- Suitable for light to medium materials
- Large horizontal axis rotary hook
- Extra wide zig-zag
- 20 inches long arm model is available

Specifications

Variety	LZ2-990 series	LZ2-992 series
Number of needle	Single needle	
Max. sewing speed	2,800 s.p.m.	2,500 s.p.m.
Max. stitch length	4.5 mm	
Zig-Zag width	0 - 9.5 mm	
Clearance under presser foot	by knee	9.0 mm
	by hand	8.0 mm
Needle Bar Stroke	34.6mm	
Needle(standard)	DP x 17 (#19)	
Thread	#30 (standard)	
Hook	Large horizontal axis hook(2.0times)	
Lubrication	Semi-automatic lubrication type	
Bed size	477 x 177 mm	
Working space	258 x 110 mm	
Net weight (Head only)	28 Kg	
Motor	Clutch motor	

NOTE: (1) Speed depends on threads, materials and type of operation
 (2) Specifications subject to change without notice



SEIKO SEWING MACHINE CO., LTD.

2-13-6, Sakaecho, Funabashi-shi
 Chiba Prefecture, 273-0018, Japan
 Phone : +81-47-420-3561 (Overseas dept.)
 Fax : +81-47-420-3560
 E-mail : export@seiko-sewing.co.jp



Printed in Japan 2016.04

<http://www.seiko-sewing.co.jp/>

SKZ series

Single needle, Heavy duty, Extra large horizontal axis hook, Reverse stitch, Zig-zag stitch(lockstitch)machines



SKZ-6B

Variety

2-point(1-step) zig-zag

  **SKZ-2B**
Upper & lower feed

  **SKZ-6B**
Drop feed

  **SKZ-6BR**
Drop feed, cloth puller

3-point(2-step) zig-zag

  **SKZ-2B-3**
Upper & lower feed

  **SKZ-6B-3**
Drop feed

  **SKZ-6BR-3**
Drop feed, cloth puller

Applications

- For sewing medium to extra heavy weight materials such as fabrics, leather, canvas, and vinyl.
- Suitable for sewing such as luggage, rope, blankets, nets(fishing net), carpets.

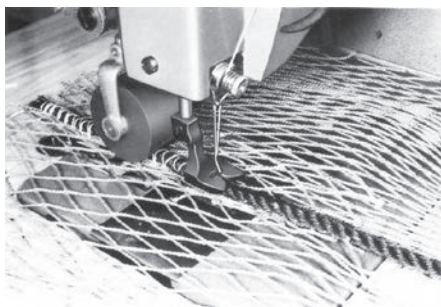

SKZ-6BR

*Suit for repairing fishing net

Puller performs exact stitching, by fixing flexible materials, thus suitable for sewing and repairing vinyl made fishing net, etc.

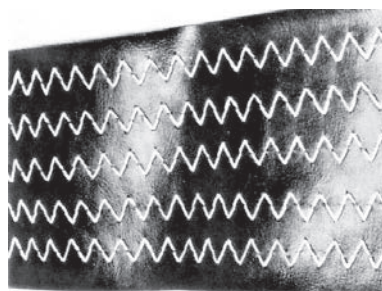

SKZ-6B-3

*Suit for sewing elastic and stretching materials

Three steps zig zag stitching suitable for sewing elastic and stretching materials on foundation. (Sewing type 308)



Features (SKZ-□)

- Suitable for ultra heavy materials
- Puller performs accurate feed for ultra heavy materials (6BR, 6BR-3)
- Large horizontal axis rotary hook
- Extra wide zig-zag
- Cording foot available
- From wider zig-zag stitch to straight stitch

*Various zig zag stitch can easily be made, from 12.7mm to 0mm straight stitch, suit to wide application.



SKZ-6B



SKZ-6B

Specifications (SKZ-□)

Variety	2B	2B-3	6B	6BR	6B-3	6BR-3
Number of needle	Single needle					
Max. sewing speed	1,000 s.p.m.					
Max. stitch length	19/64" (7.5 mm)	5/32" (4 mm)	19/64" (7.5 mm)			
Zig-Zag width	0 -1/2" (0 -12.7 mm)					
Clearance under presser foot	by knee		7/16" (11 mm)			
	by hand		25/64" (10 mm)			
Needle bar stroke	2" (50.8 mm)					
Needle (standard)	DD x H14 (#25)					
Thread	#5 (standard)					
Hook	Extra large horizontal axis hook					
Thread take up lever	Link type					
Lubrication	Hand type					
Bed size	20-33/64"x 9-59/64" (521 x 252 mm)					
Working space	10"x 7- 43/64" (254 x 195 mm)					
Motor	Clutch motor					

NOTE: (1) Speed depends on threads, materials and type of operation
 (2) Specifications subject to change without notice



SEIKO SEWING MACHINE CO., LTD.

2-13-6, Sakaecho, Funabashi-shi
 Chiba Prefecture, 273-0018, Japan

Phone : +81-47-420-3561 (Overseas dept.)

Fax : +81-47-420-3560

E-mail : export@seiko-sewing.co.jp

Printed in Japan 2016.04

<http://www.seiko-sewing.co.jp/>

BEW Long arm series

Long (30 inch) arm, Large vertical axis hook, Compound feed and walking foot, Reverse stitch, Lockstitch sewing machines.



BEW-8BLCS-30-BTFL-CD-DS

Variety



BEW-8BLCS-30-BTFL-CD-DS

Single needle, thread trimmer, automatic back tack, automatic presser foot lift, climbing device, dual stitching device



BEW-28BLCS-30-BTFL-CD-DS

Two needle, thread trimmer, automatic back tack, automatic presser foot lift, climbing device, dual stitching device

Applications

- For sewing medium to heavy weight materials such as leather, vinyl, synthetics and laminated and coated materials
- Suitable for sewing such as automobile upholstery, tarpaulins, covers, awnings, tents, umbrellas handbags, luggage, travelware accessories, sports and camping equipment and wearing apparel outdoor clothing.

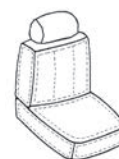

BEW Long arm series

Features

- 30 inch long arm, Longer stitch length quiet sewing operation. Max. 9 mm for both forward and reverse feed stitching.
- BEW series are equipped with a large vertical axis hook (2.0 times).
- Safety device & Reliable thread trimming device & One touch switchover for two different stitch lengths. (DS device)
- Built-in bobbin winder & Wide working space (768 mm).
- Large clearance under presser foot. Presser bar lifter.
- 5 operational switches improve working efficiency.
- E type presser foot is available as an option. (BEW-8BLCS-30-BTFL-CD-DS only)
- Simple setting for alternating presser foot movement. Smooth stitching on step section (CD device).

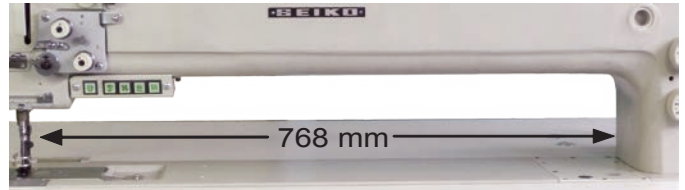

Specifications (BEW-□)

Variety		8BLCS-30-BTFL-CD-DS	28BLCS-30-BTFL-CD-DS
Number of needle		Single needle	Two needle
Max. sewing speed		2,000 s.p.m.	
Max. stitch length		9 mm	
Clearance under presser foot	by hand	9 mm	
	by automatic foot lifter	16 mm	
Needle bar stroke		37 mm	
Needle (Standard)		135×17 #110 - #200 (#160), DP×17 #18 - #25 (#23)	
Thread		#30 - #1 (Standard #5)	
Hook		Large vertical axis hook (2.0 times)	
Thread length after trimming		27 mm	
Thread take up lever		Slide type	
Amount of walking foot movement		1 - 7 mm	
Walking foot movement change switch		Dial type	
Bobbin winder		Built-in type located at the top of the sewing machine	
Auto presser foot lifting device		Pneumatic	
Walking foot movement change device		Pneumatic	
Safety device		Standard	
Lubrication		Automatic lubrication type	
Bed size / Working space		1033 × 177 mm / 768 × 120 mm	
Net weight (Head only)		74 Kg	75 Kg
Motor		AC Servo motor	

NOTE: (1) Speed depends on threads, materials and type of operation
 (2) Specifications subject to change without notice



SEIKO SEWING MACHINE CO., LTD.

2-13-6, Sakaecho, Funabashi-shi
 Chiba Prefecture, 273-0018, Japan

Phone : +81-47-420-3561 (Overseas dept.)

Fax : +81-47-420-3560

E-mail : export@seiko-sewing.co.jp



Printed in Japan 2016.04

<http://www.seiko-sewing.co.jp/>

JW series

Extra heavy duty, Extra long arm, Extra large vertical axis hook, Compound feed and walking foot, Reverse stitch, Lockstitch machines

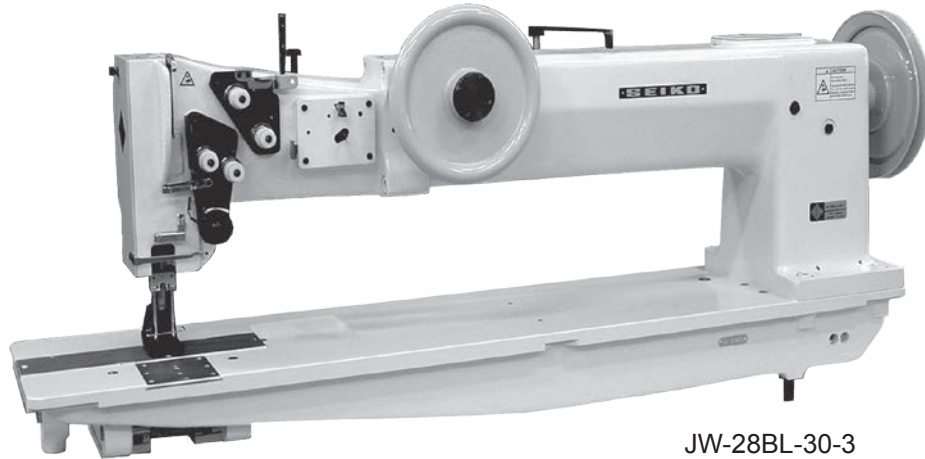

JW-28BL-30-3

Variety



JW-8BL-30-3

Single needle, 30 inch machine arm



JW-8BLA-30-3

Single needle, 30 inch machine arm, for thick thread



JW-28BL-30-3

Two needle, 30 inch machine arm



JW-28BLA-30-3

Two needle, 30 inch machine arm, for thick thread

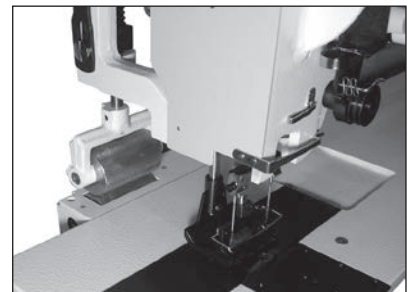

Clutch driven puller feed

Applications

- For sewing extra heavy weight materials such as canvas, vinyl, leather, synthetics, and various coated, laminated and rubberized fabric.
- Suitable for sewing such as tents, tarps, awnings, truck covers, auto marine and furniture upholstery, field covers, fabric structures and heavy bulky products.

Features

- Long and wide working space is suitable for sizable materials such as tent and sail cloth.
- Extra large vertical axis hook with automatic lubrication.
- Compound feed and walking foot mechanism assures even feeding of materials.
- Double thread tension.
- Safety clutch prevents the hook from being damaged.
- Reverse feed operated by foot pedal.
- Push button stitch regulator.
- Built-in bobbin winder.
- Front handwheel allows for easy positioning of the needle.
- Cloth puller available as option. Add suffix "R" when ordering.
- Automatic back tack (BT) and foot lift (FL) available as option. Add suffix "BT" and "FL" when ordering.

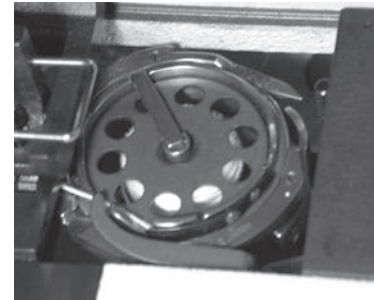

Extra large vertical axis hook

Specifications (JW-□)

Variety	8BL-30-3	28BL-30-3	8BLA-30-3	28BLA-30-3
Number of needle	Single needle	Two needle	Single needle	Two needle
Max. sewing speed	1,200 s.p.m.		1,000 s.p.m.	
Max. stitch length	25/64" (10 mm)			
Clearance under presser foot	by pedal			
	by hand			
Needle bar stroke	1-27/32" (46.8 mm)			
Needle(standard)	DYx3 (#24)		DYx3 (#29)	
Thread	upper #8 - #0 (standard #5) lower #8		upper #5 - 1.4 mm lower #5	
Hook	Special extra large vertical axis hook			
Amount of lift of walking foot	15/64" - 11/32" (6 mm - 9 mm)		standard 15/64" (standard 6 mm)	
Thread take up lever	Slide type			
Lubrication	Semi-automatic lubrication type			
Bed size	43 - 5/16" x 9 - 1/16" (1,100 x 230 mm)			
Working space	30" x 6 - 1/32" (762 x 153 mm)			
Motor	Clutch motor		Clutch motor AC Servo motor	

NOTE: (1) Speed depends on threads, materials and type of operation (2) Specifications subject to change without notice

Needle gauge list

Variety	Needle gauge size
JW-28BL-30-3	Standard : 1/4"(6.4 mm), 5/16"(7.9 mm), 3/8"(9.5 mm), 1/2"(12.7 mm), 3/4"(19 mm)
JW-28BLA-30-3	Standard : 3/4"(19 mm)

Note: Other needle gauges are available within 5/8" to 1-1/2" at extra cost.



SEIKO SEWING MACHINE CO., LTD.

2-13-6, Sakaecho, Funabashi-shi
Chiba Prefecture, 273-0018, Japan
Phone : +81-47-420-3561 (Overseas dept.)
Fax : +81-47-420-3560
E-mail : export@seiko-sewing.co.jp

Printed in Japan 2016.04

<http://www.seiko-sewing.co.jp/>

LCW long arm series

High speed, Cylinder bed, Large vertical axis hook, Compound feed and walking foot, Reverse stitch, Lockstitch machines

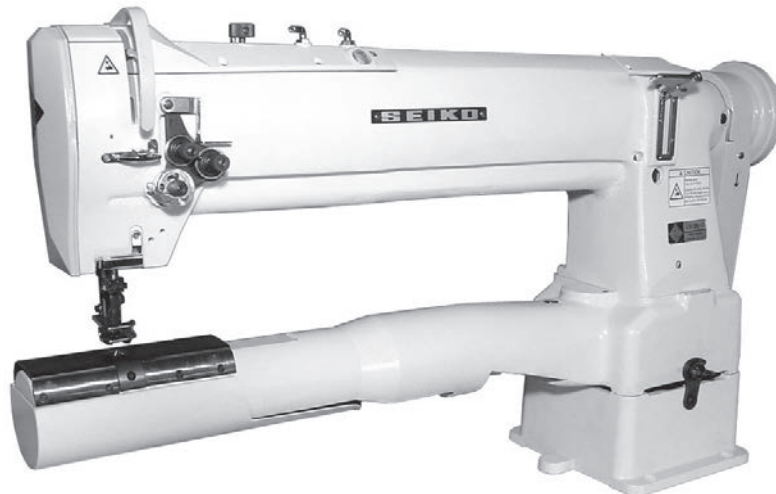

LCW-28BL-20

Variety

LCW-28BL-20
20inch long arm

LCW-28BL-30
30inch long arm

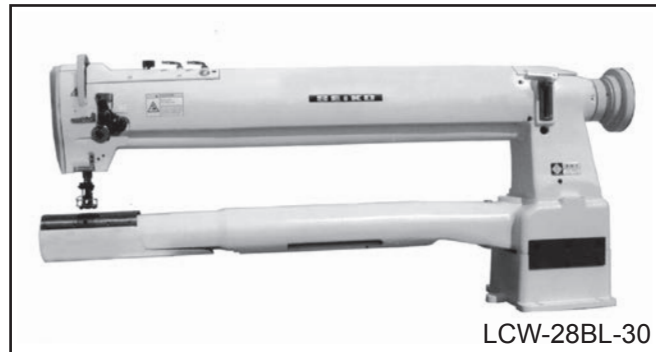

LCW-28BL-30

Applications

- For sewing medium to heavy weight fabrics, leather, synthetics, canvas and various coated and laminated materials.
- Suitable for sewing tubular and curved work such as shoes boots, bags, handbags, filters and ducting.



LCW long arm series

Features

- Semi-automatic lubrication system.
- Large vertical axis hook.
- Safety clutch prevents the hook from being damaged.
- Reverse stitching by stitch adjusting lever.

Specifications (LCW-□)

Variety	28BL-20	28BL-30
Number of needle	Two needle	
Max. sewing speed	1,500 s.p.m.	1,300 s.p.m.
Max. stitch length	1/4" (6.2 mm)	
Clearance under presser foot	by pedal 35/64" (14 mm)	
	by hand 21/64" (8.5 mm)	
Needle bar stroke	1-5/16" (33.2 mm)	
Needle(standard)	DPx17 (#22) , 135x17 (#140)	
Thread	#8 (standard)	
Hook	Large vertical axis hook(2.0times)	
Amount of lift of walking foot	7/64"-7/32" (2.7 - 5.5 mm)	standard 1/8" (standard 3.2 mm)
Thread take up lever	Slide type	
Lubrication	Semi-automatic lubrication type	
Cylinder size	3-7/64"(79 mm) dia.	
Working space	20"x 4-21/64" (508 x 110 mm)	30"x 4-21/64" (762 x 110 mm)
Motor	Clutch motor	
Net weight(Head only)	50Kg	65Kg

NOTE: (1) Speed depends on threads, materials and type of operation
(2) Specifications subject to change without notice

Needle gauge list (LCW-□)

Variety	Needle gauge size
28BL-20 28BL-30	standard : 1/4"(6.4 mm), 5/16"(7.9mm), 3/8"(9.5mm), 1/2"(12.7mm)



SEIKO SEWING MACHINE CO., LTD.

2-13-6, Sakaecho, Funabashi-shi
Chiba Prefecture, 273-0018, Japan

Phone : +81-47-420-3561 (Overseas dept.)

Fax : +81-47-420-3560

E-mail : export@seiko-sewing.co.jp

Printed in Japan 2016.04

<http://www.seiko-sewing.co.jp/>

LSWNH series

High speed, Compound feed and walking foot, Reverse stitch, Large vertical axis hook, High and long arm lockstitch machines.

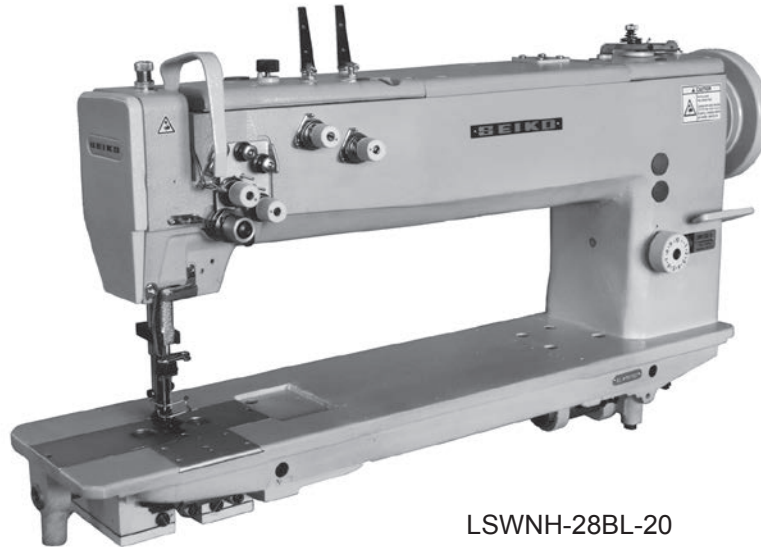

LSWNH-28BL-20

Variety



LSWNH-8BL-20

Single needle



LSWNH-8BL-20-BTFL

Single needle, automatic back tack, automatic presser foot lift



LSWNH-8BL-20-TA-BTFL

Single needle, automatic back tack, automatic presser foot lift, for thick thread



LSWNH-28BL-20

Two needle



LSWNH-28BL-20-BTFL

Two needle, automatic back tack, automatic presser foot lift



LSWNH-28BL-20-TA-BTFL

Two needle, automatic back tack, automatic presser foot lift, for thick thread

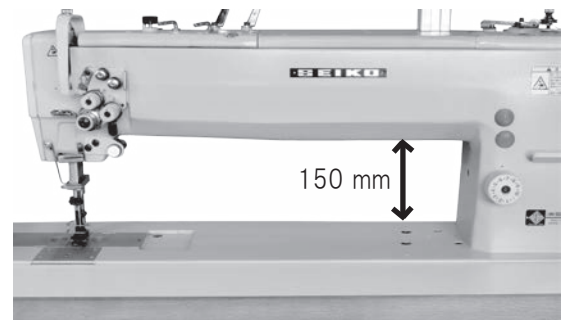

Applications

- For sewing medium to heavy weight materials such as leather, vinyl, synthetics and laminated and coated materials.
- Suitable for sewing such as tents, covers, sails, awnings, tarpaulins, automobile upholstery.

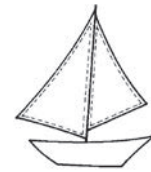
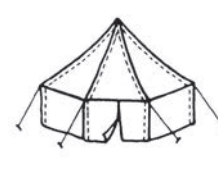
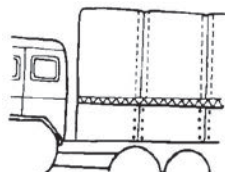

LSWNH series

Features (LSWNH-□)

- Standard equipment of long stitch (max.10mm) suitable for thick material and amount of alternative presser lift (max.6mm).
- Adoption of feed-adjusting dial which eases determination process of stitch length.
- Plain needle drop area/adoption of open/close simplified face plate which provides wide-ranged movement of sewn material.
- Advanced penetration required for sewing of thick material/adoption of large pulley (O.D. 150mm) which enables the needle bar to be positioned properly.
- Built-in bobbin winder makes it possible to wind the bobbin thread during sewing operation.
- Large capacity hook (2.0 times/Automatic hook lubrication) minimized the time to replace the bobbin thread.
- Safety clutch prevents the hook from being damaged.

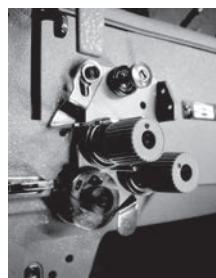

Single needle

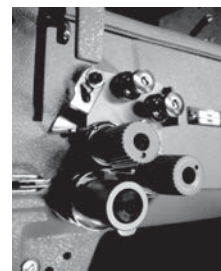

Two needle

Specifications (LSWNH-□)

Variety	8BL-20	8BL-20-BTFL	8BL-20-TA-BTFL	28BL-20	28BL-20-BTFL	28BL-20-TA-BTFL
Number of needle	Single needle			Two needle		
Max. sewing speed	1,500 s.p.m.		1,300 s.p.m.	1,500 s.p.m.		1,300 s.p.m.
Max. stitch length	25/64" (10 mm)					
Clearance under presser foot	by pedal		5/8" (16 mm)			
	by hand		9/64" (8.5 mm)			
Needle bar stroke	1-25/64" (35.4 mm)					
Needle(standard)	DP x 17(#22) 135 x 17(#140)		DP x 17(#24) 135 x 17(#180)	DP x 17(#22) 135 x 17(#140)		DP x 17(#24) 135 x 17(#180)
Thread	#8 (standard)					
Hook	Large vertical axis hook(2.0times)					
Amount of lift of walking foot	1/8"-15/64" standard 5/32" (3 - 6 mm) (standard 4 mm)					
Thread take up lever	Slide type					
Lubrication	Semi-automatic lubrication type					
Bed size	30-45/64" x 7-1/64" (780 x 178 mm)					
Working space	20-5/16" x 5-29/32" (516 x 150 mm)					
Motor	Clutch motor					
Net weight(Head only)	65Kg		66Kg	67Kg		68Kg

NOTE: (1)Speed depends on thread, materials and type of operations.

(2)Specifications subject to change without notice.



SEIKO SEWING MACHINE CO., LTD.

2-13-6, Sakaecho, Funabashi-shi
Chiba Prefecture, 273-0018, Japan

Phone : +81-47-420-3561 (Overseas dept.)

Fax : +81-47-420-3560

E-mail : export@seiko-sewing.co.jp

Printed in Japan 2016.04

<http://www.seiko-sewing.co.jp/>

SK-2B-1-20

Single needle, Extra heavy duty, 20 inch long arm,
Large horizontal axis hook, Drop feed and walking foot,
Reverse stitch, Lockstitch machines

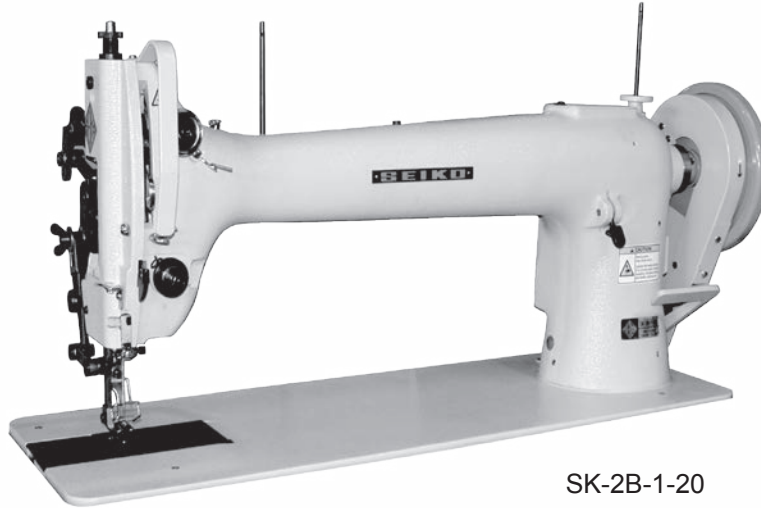

SK-2B-1-20

Variety

SK-2B-1-20

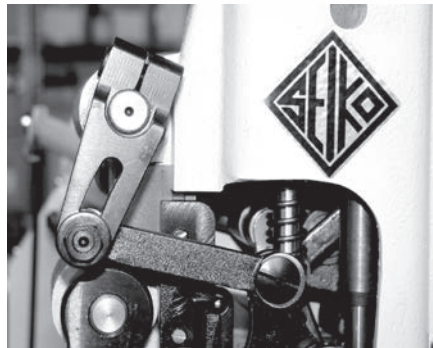

Alternating presser foot lift relative parts

Applications

- For sewing heavy weight leather, canvas, vinyl, and various coated and laminated fabrics
- Suitable for sewing such products as harnesses, covers, safety belts, tents, sheets, gloves, buffs, and heavy duty travel bags.

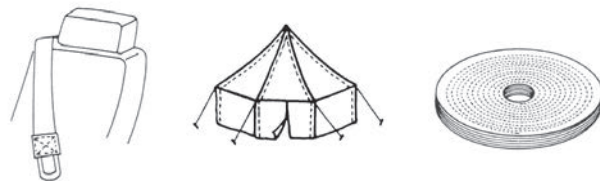

Features

- Horizontal axis rotary hook with extra large capacity bobbin minimizes the time to replace the bobbin thread.
- SK series is the powerful sewing machine in the SEIKO specially designed for ultra heavy duty materials.

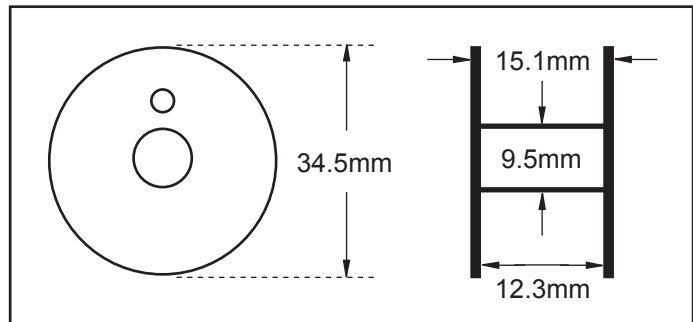

Large bobbin

Specifications

Variety	SK-2B-1-20	
Number of needle	Single needle	
Max. sewing speed	900 s.p.m.	
Max. stitch length	1/2" (13 mm)	
Clearance under presser foot	by pedal	35/64" (14 mm)
	by hand	1/2" (13 mm)
Needle bar stroke	2" (50.8 mm)	
Needle(standard)	DDx1 (#24) , 328 (#180)	
Thread	#0 - #5 (standard #5)	
Hook	Large horizontal axis hook	
Amount of lift of presser foot	1/8"-15/64" (3 - 6 mm) (standard 4mm)	
Thread take up lever	Link type	
Lubrication	Hand type	
Bed size	30-35/64" x 9-61/64" (776 x 253 mm)	
Working space	20-5/64"x 7-31/64" (510 x 190 mm)	
Motor	Clutch motor	
Net weight(Head only)	71 Kg	

NOTE: (1) Speed depends on threads, materials and type of operation
 (2) Specifications subject to change without notice



SEIKO SEWING MACHINE CO., LTD.

2-13-6, Sakaecho, Funabashi-shi
 Chiba Prefecture, 273-0018, Japan
 Phone : +81-47-420-3561 (Overseas dept.)
 Fax : +81-47-420-3560
 E-mail : export@seiko-sewing.co.jp



Printed in Japan 2016.04

<http://www.seiko-sewing.co.jp/>

LDA series

High speed, Feed-off-the-arm, Drop feed,
Double chain stitch machines

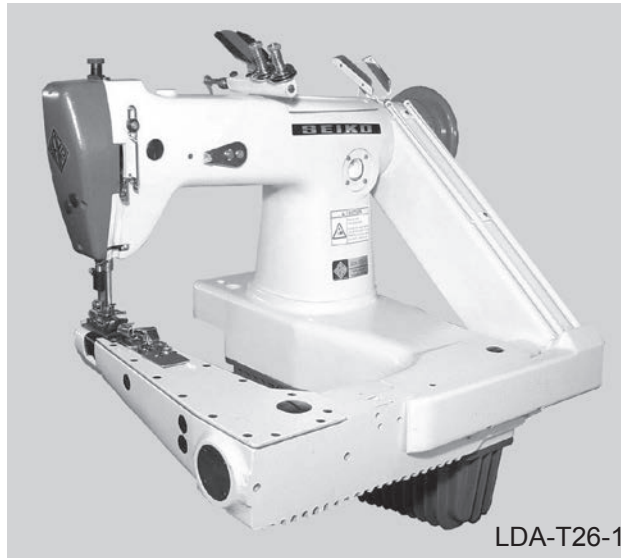

LDA-T26-1

Variety



LDA-L26-1

Two needle, for light weight materials



LDA-T26-1

Two needle, for heavy weight materials



LDA-T26-1

Applications

- For sewing light to heavy weight materials
- Suitable for sewing shirts, sleep suit, jeans, pants, skirts, uniforms, heavyoveralls, raincoats, difficult to sew tubular products, etc.

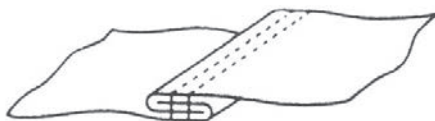

LDA-T26-1

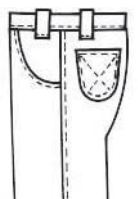
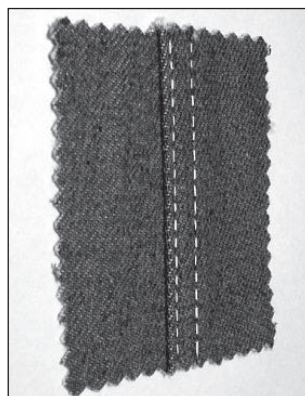

Features

- Fully automatic lubrication
- Clear, unobstructed view of work area for operator with ample work space to right of needles
- Easy access to stitch regulator and looper avoiding motion adjustment
- Oil flow window indicates oil circulation
- Non-slip belt drive to bed mechanism assures smooth, positive power feeding
- Under threading readily accessible through hinged covers

Specifications (LDA-□)

Variety	L26-1	T26-1
Number of needle	Two needle	
Max. sewing speed	6,500 s.p.m.	5,000 s.p.m.
Max. stitch length	7/16" (2.5 mm)	11/64" (4.2 mm)
Clearance under presser foot	1/4" (6.4 mm)	5/16" (8 mm)
Needle bar stroke	1-1/16" (27 mm)	1-5/16" (33.3 mm)
Needle(standard)	TVx7 (#16), 149x7 (#100)	TVx3 (#21), 149x3 (#130)
Thread	#40 (standard)	#20 (standard)
Lubrication	Full automatic lubrication type	
Motor	Clutch motor	

NOTE: (1) Speed depends on threads, materials and type of operation
 (2) Specifications subject to change without notice

Needle gauge list (LDA-□)

Variety	Needle gauge size
L26-1, T26-1	standard : 3/16"(4.8mm) , 1/4"(6.4mm)



SEIKO SEWING MACHINE CO., LTD.

2-13-6, Sakaecho, Funabashi-shi
 Chiba Prefecture, 273-0018, Japan

Phone : +81-47-420-3561 (Overseas dept.)

Fax : +81-47-420-3560

E-mail : export@seiko-sewing.co.jp

Printed in Japan 2016.04

<http://www.seiko-sewing.co.jp/>







LD series







High speed, Full automatic lubrication, Flat bed, Double chain stitch machines



LD-27R

Variety

- | | |
|---|---|
|  | LD-7
Single needle, Compound feed |
|  | LD-27
Two needle, Compound feed |
|  | LD-37
Three needle, Compound feed |
|  | LD-47
Four needle, Compound feed |
|  | LD-57
Five needle, Compound feed |
|  | LD-67
Six needle, Compound feed |

- | | |
|---|--|
|  | LD-8
Single needle, Compound feed and walking foot |
|  | LD-28
Two needle, Compound feed and walking foot |
|  | LD-38
Three needle, Compound feed and walking foot |
|  | LD-48
Four needle, Compound feed and walking foot |
|  | LD-58
Five needle, Compound feed and walking foot |
|  | LD-68
Six needle, Compound feed and walking foot |

Applications

- For sewing medium to heavy weight fabrics, leather, canvas, denim, synthetics, and various coated and laminated materials.
- Suitable for automobile upholstery, work gloves, luggage, trousers, carpets, mattresses, etc.



Features

- Simplified looper throw-out.
- Easy accessibility for threading loopers.
- No bobbin winding or changing (double chain stitch)
- Coarse stitch(7.5 - 10mm stitch) version available on model LD-8.
- Ultra long arm version (SSLD series) available
- Cloth puller available. Add suffix "R" when ordering.

Specifications (LD-□)

Variety	□7	□8
Number of needle	1 to 6	
Max. sewing speed	3,000 s.p.m.	
Max. stitch length	19/64" (7.5 mm)	
Clearance under presser foot	by knee	33/64" (13 mm)
	by hand	5/16" (8 mm)
Needle bar stroke	1-3/8" (35 mm)	
Needle(standard)	DVx59 (#22) , 62x59 (#140)	
Thread	#8 (standard)	
Amount of lift of walking foot	-	5/64" - 9/64" standard 3/32" (1.8 - 3.5 mm) (standard 2.5 mm)
Thread take up lever	Needle bar type	
Lubrication	Semi-automatic lubrication type	
Bed size	20-25/64" x 6-31/32" (518 x 177 mm)	
Working space	10-5/8" x 5-5/16" (270 x 135 mm)	
Motor	Clutch motor	
Net weight(Head only)	43Kg	

NOTE: (1) Speed depends on threads, materials and type of operation
(2) Specifications subject to change without notice

Needle gauge list (LD-□)

Variety	Needle gauge size
27 , 28	standerd : 1/4"(6.4 mm), 5/16"(7.9 mm), 3/8"(9.5 mm), 1/2"(12.7 mm)



SEIKO SEWING MACHINE CO., LTD.

2-13-6, Sakaecho, Funabashi-shi
Chiba Prefecture, 273-0018, Japan
Phone : +81-47-420-3561 (Overseas dept.)
Fax : +81-47-420-3560
E-mail : export@seiko-sewing.co.jp

Printed in Japan 2016.04

<http://www.seiko-sewing.co.jp/>

SSLD series

Heavy duty, Ultra long arm, Compound feed and walking foot,
Clutch driven puller feed, Double chain stitch machines

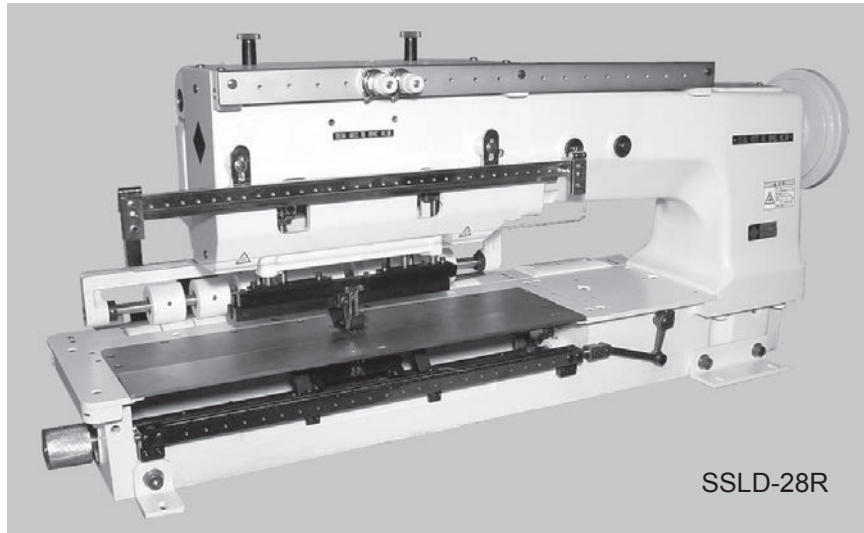

SSLD-28R

Variety



SSLD-□8R

2~9 needles



SSLD-□□8R

10~18 needles

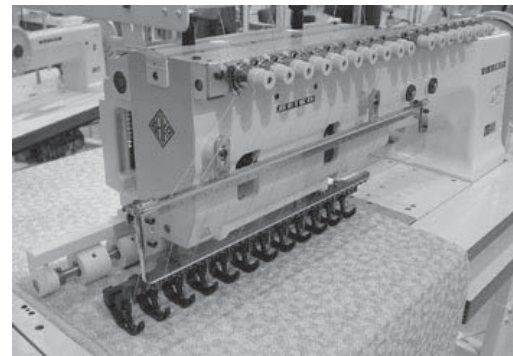

SSLD-128R-FL

* Min. distance between needles is 1/4"(6.4mm).

Applications

- For sewing medium to heavy weight fabric, leather, canvas, denim, synthetics, and various coated and laminated materials.
- Suitable for automobile upholstery, carpets, mattresses, etc.

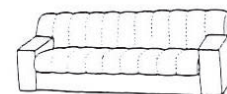

Features

- Ultra long arm, working space 20 inch (508 mm)
 - Compound feed and alternating presser foot mechanism ensures even feeding of heaviest and most slippery articles to be sewn
 - Heavy duty top and bottom puller ensures accurate and efficient feeding
 - No bobbin winding or changing (double chain stitch)
 - Automatic presser foot lift (FL) available
- * Special gauge parts (from 2 needles to 70 needles) within overall gauge size 18 inch (460mm) can be made upon request. However, maximum number of needle which can use at a time must be 18 needles due to functional specification.
- * SSLD series is completely made-to-order. The number of needle and their needle distance are required to estimate the machine price.

Specifications

Variety	SSLD-series
Number of needle	2 to 18
Max. sewing speed	1,200 s.p.m.
Max. stitch length	23/64" (9 mm)
Clearance under presser foot	19/32" (15 mm)
Needle bar stroke	1-17/32" (39 mm)
Needle(standard)	DV x 59 (#22) , 62 x 59 (#140)
Thread	#8 (standard)
Thread take up lever	Needle bar type
Amount of lift of walking foot	5/64"-15/64" standard 9/64" (2 - 5.8 mm) (standard 3.6 mm)
Lubrication	Semi-automatic lubrication type
Bed size	38-37/64" x 7-31/64" (980 x 190 mm)
Working space	20" x 4-51/64" (508 x 122 mm)
Motor	Clutch motor

NOTE: (1) Speed depends on threads, materials and type of operation
 (2) Specifications subject to change without notice



SEIKO SEWING MACHINE CO., LTD.

2-13-6, Sakaecho, Funabashi-shi
 Chiba Prefecture, 273-0018, Japan
 Phone : +81-47-420-3561 (Overseas dept.)
 Fax : +81-47-420-3560
 E-mail : export@seiko-sewing.co.jp



Printed in Japan 2016.04

<http://www.seiko-sewing.co.jp/>

HVP-i70

AC servo motor for “SEIKO” machine



Features

- Simple and easy to use for “SEIKO” machines.
(Pre-setting the necessary parameters for “SEIKO” Models then only setting the machine code number when initial operation.)
- Low noise, low vibration and low power consumption.
- Highly accurate positioning.
- Specification matched the “CE” Standard.
- Without synchronizer(if damaged), motor working as Clutch motor and the backtack solenoid & auto-foot lifter still working.
- Solenoid over current protected.
- Fully digital design, powerful parameter built-in for application.
- With O.V. ,O.C. ,L.V. protection function and controlled by software.
- With auto-running timer inside, easy to test. (Function no.135, 136, 137 & 138)
- Easy to maintain through error cord display.

Dimension

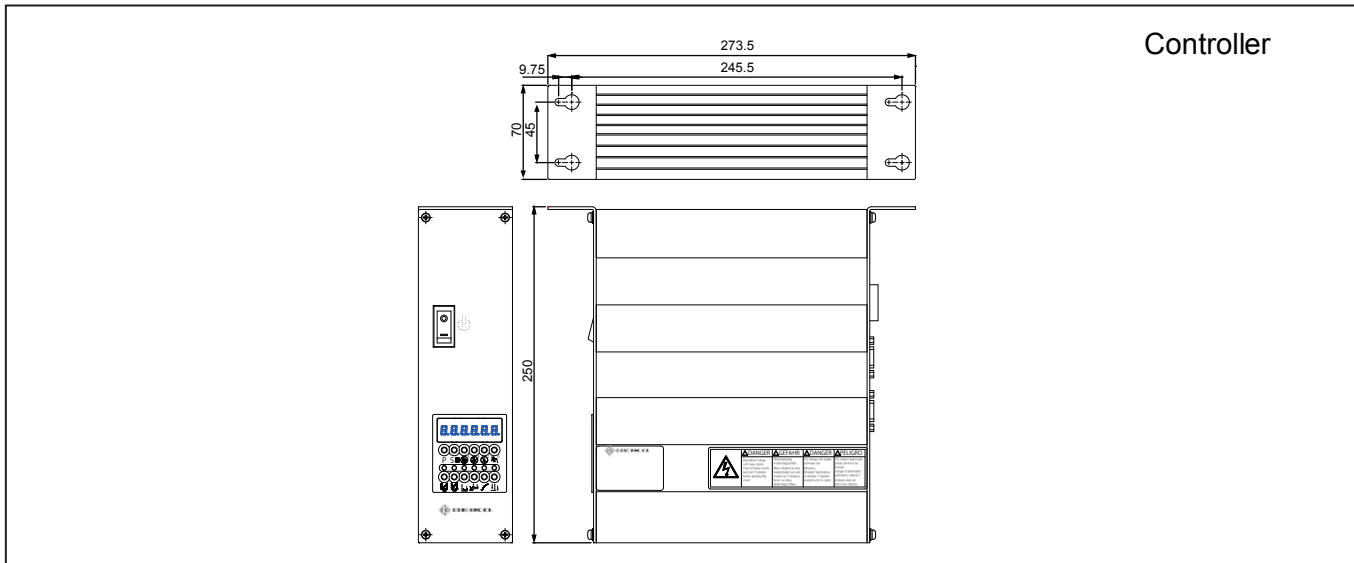

Controller

Option Parts

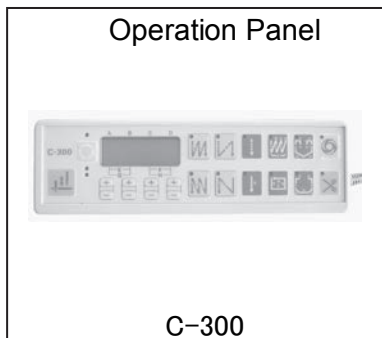
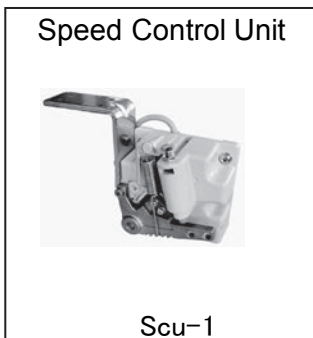

Specification

Rated speed(r.p.m)	3,500
Rated output(W)	750
Power voltage range(V)	single phase 100-120/200-240
Pully size available(mm)	55-85
Output shaft	Straight shaft Φ 14
Gross weight(Kg)	10.9
Packing dimension(mm)	400L X 320W X 430H

Features

- Auto pressr foot lift
- Thread trimmer
- Auto back tack
- Climbing device
- Dual stitching device
- Needle up/down
- Slow start
- DC12V lamp output



SEIKO SEWING MACHINE CO., LTD.

2-13-6, Sakaecho, Funabashi-shi
Chiba Prefecture, 273-0018, Japan

Phone : +81-47-420-3561 (Overseas dept.)

Fax : +81-47-420-3560

E-mail : export@seiko-sewing.co.jp



Printed in Japan 2016.04

<http://www.seiko-sewing.co.jp/>

HVP-i90

AC servo moter for “SEIKO” extra heavy duty machine

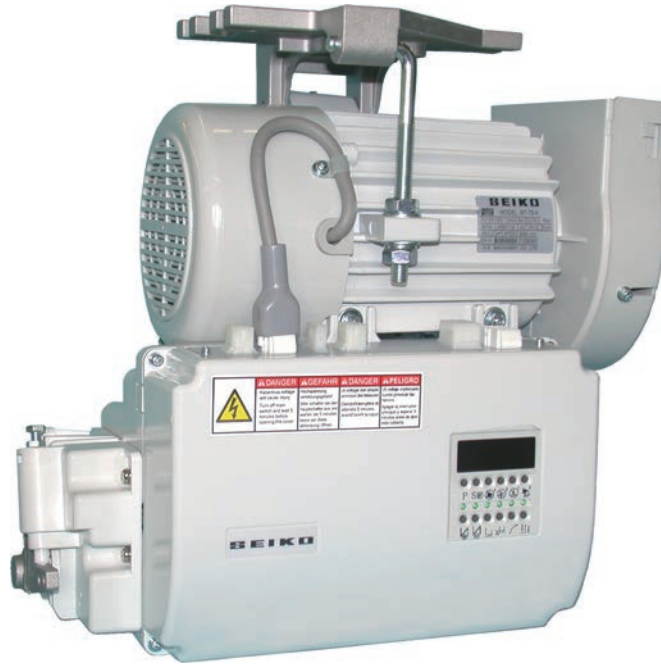



Features

- Simple and easy to use for “SEIKO” extra heavy duty machines.
- Stable stopping accuracy.
- Low noise, low vibration and low power consumption.
- Specification matched the “CE” Standard.
- Solenoid over current protected.
- Software / Hardware 2-way protection system.
- Easy to maintain through error cord display.

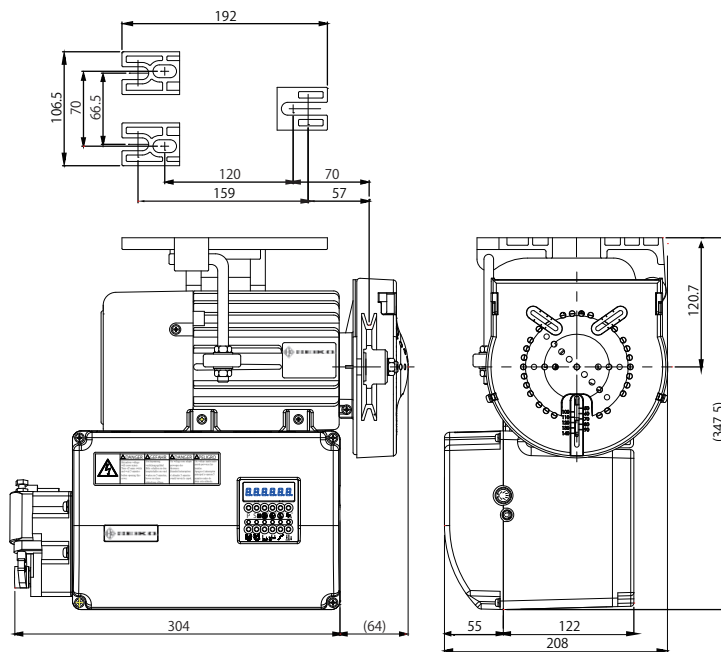
Dimension



Option Parts

<p>Synchronizer</p>  <p>600-32</p>	<p>Standing operation pedal</p>  <p>SOP-6H</p>	<p>Operation panel</p>  <p>Standard C-300M</p>
---	--	---

Specification

Rated speed(r.p.m)	2,000
Rated output(W)	750
Power voltage range(V)	single phase 100-120/200-240
Pully size available(mm)	65-130 (standard 65)
Output shaft	Taper shaft
Gross weight(Kg)	11.5
Packing dimension(mm)	424L X 409W X 355H

Features

- Auto pressr foot lift
- Thread trimmer
- Auto back tack
- Climbing device
- Dual stitching device
- Needle up/down
- Slow start



SEIKO SEWING MACHINE CO., LTD.

2-13-6, Sakaecho, Funabashi-shi
 Chiba Prefecture, 273-0018, Japan
 Phone +81-47-420-3561 (Overseas dept.)
 Fax +81-47-420-3560
 E-mail export@seiko-sewing.co.jp



Printed in Japan 2016.04

<http://www.seiko-sewing.co.jp/>



SEIKO SEWING MACHINE CO., LTD.

2-13-6 Sakaecho, Funabashi-shi,
Chiba 273-0018, JAPAN
Phone: +81-47-420-3561 (Export dept.)
Fax: +81-47-420-3560

E-mail: export@seiko-sewing.co.jp

<http://www.seiko-sewing.co.jp>

